



NEW

Low Cost Actuator

Electrical/Motion Cylinder

VLA

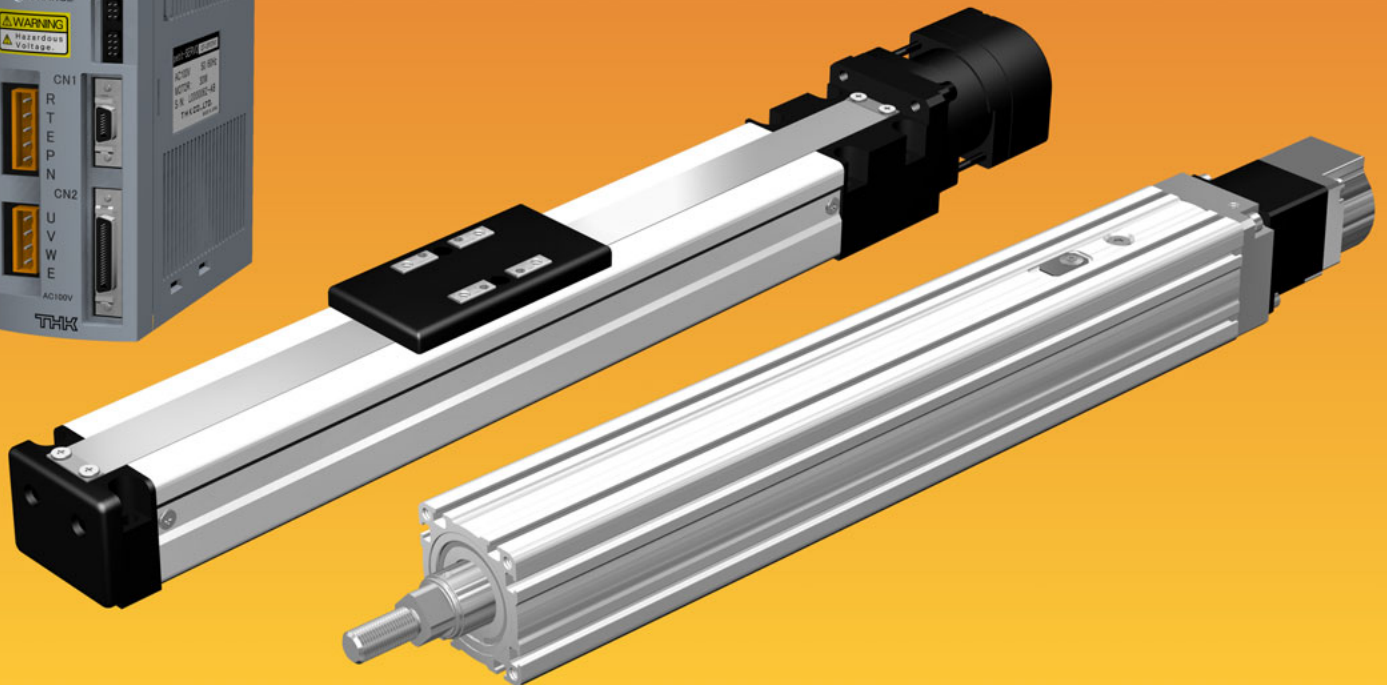

Low Cost VLA

Actuator assembly types

Choose from two assembly designs.

VLA-ST Slider Type

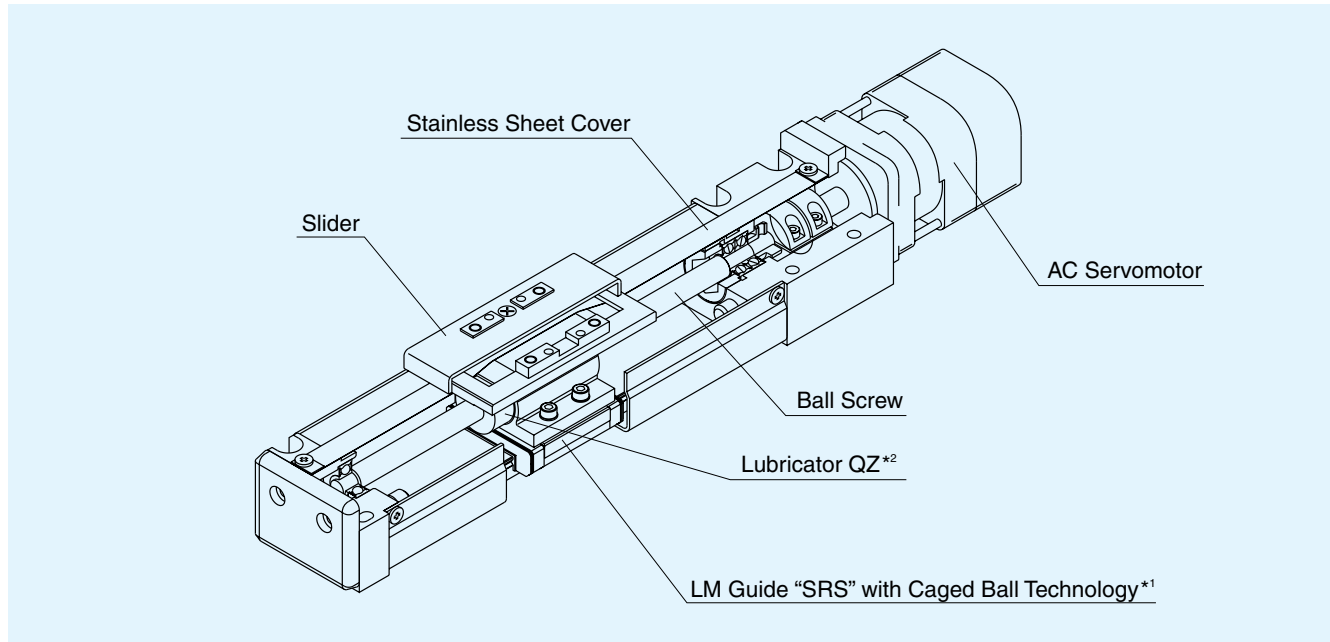

VLA-CT Cylinder Type

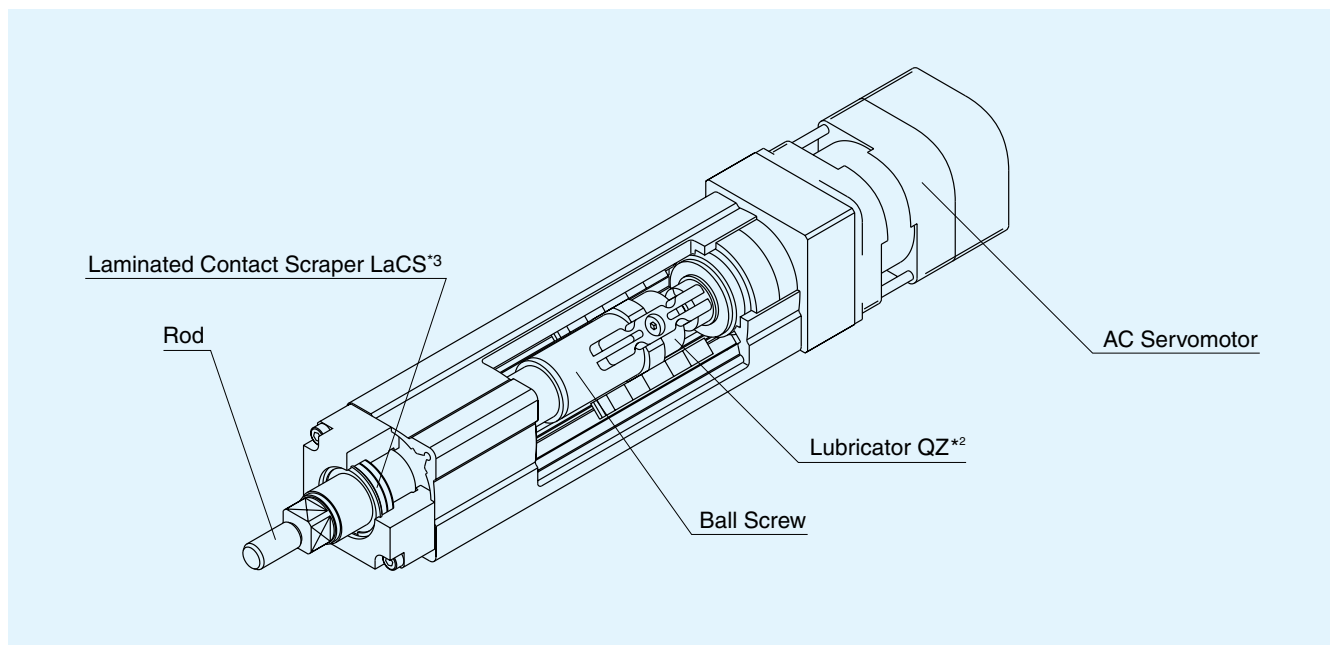

Type Actuator

VLA Features & Benefits

● Simple Design, Low Cost

Incorporating an LM guide rail as the actuator's base, reduces the number of assembly components to provide a simple, light-weight, and cost effective actuator.

● Simple Control Method

- Multiple precision point positioning is easily obtained with simple ON/OFF signals to the controller QT.

● Durability & Long Term Maintenance Free

- With THK's Caged Ball Technology, this actuator offers a robust design and long maintenance intervals.

● Environmentally Friendly & Energy Efficient

- Replacing pneumatic cylinders with electro-mechanical components, offers cleaner, quieter & energy efficient operation. Contamination from lubricants, exhaust will be eliminated.

● High performance, High Productivity

- The AC servo drive/motor package, offers high speed operation and accurate resolution resulting in high productivity.

● Universal, Flexible

- Compatible with most popular servo. Easily integrates with your specific design.

*1: Caged Ball LM Guide model SRS

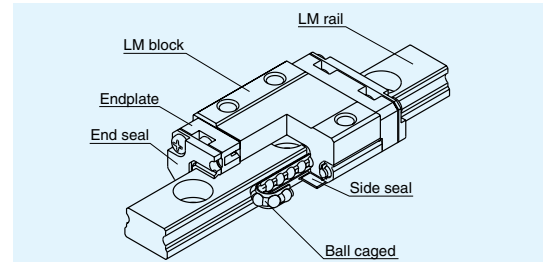

With model SRS, use of ball cages eliminates friction between balls and allows the following effects to be obtained.

- 1) Low noise, acceptable running sound
- 2) Long-term maintenance-free operation
- 3) High-speed response, long service life
- 4) Excellent smoothness
- 5) Low dust generation

*2: Lubricator QZ

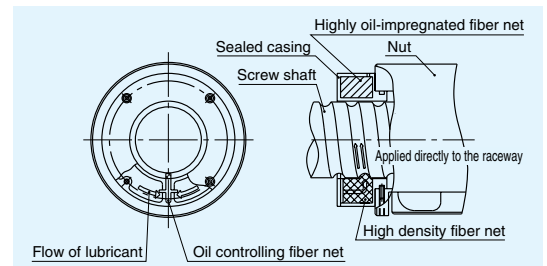

- 1) Substantially extended maintenance interval

With ordinary grease lubrication for a ball screw, slight amount of oil is lost as the ball screw travels. Attaching QZ Lubricator supplements oil loss over a long period and allows the maintenance intervals to be significantly extended.

- 2) Eco-friendly lubrication system

QZ Lubricator feeds the right amount of oil to the right location with a high density fiber net, making itself an eco-friendly lubrication system that does not waste oil.

*3: Laminated Contact Scraper LaCS

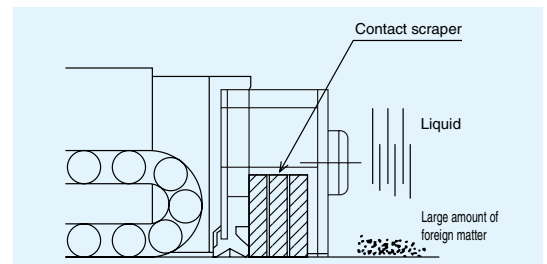

With a laminated contact structure (2-layer scraper), LaCS removes minute foreign matter adhering to the LM rail in multiple stages to prevent it from entering the LM block.

Low noise, acceptable running sound

- Since 2-layer scrapers are in full contact with the LM rail, LaCS is highly capable of removing minute foreign matter.
- Use of oil-impregnated expanded synthetic rubber with self-lubricating capability achieves a low frictional resistance.

System Components

□ Actuator: VLA-CT Type

Cylinder Type

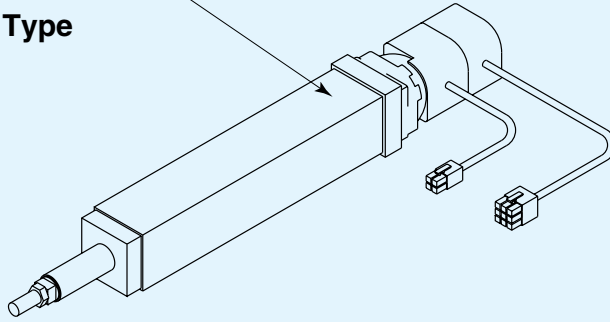

□ Actuator: VLA-ST Type

Slider Type

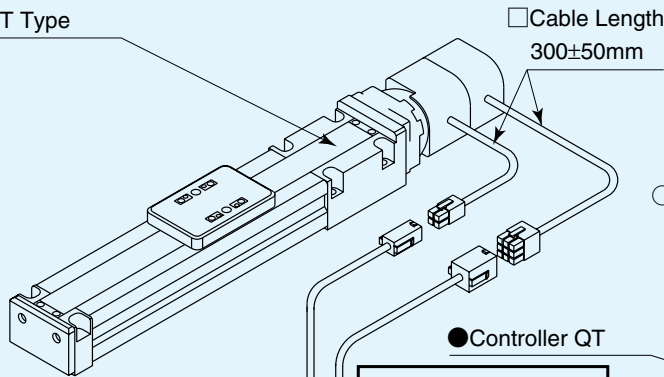

◎ Motor Power Cable
TH-MCB03
Option

◎ Motor Encoder Cable
TH-ECB03
Option

● Power Supply Connector
231-305/026-000
Dedicated ferrule
216-205
Provided with the controller

○ Line Cable
TH-PWB03
Option (3m)

● I/O Connector Plug
10136-3000VE
Dedicated cover
10336-52F0-008
Provided with the controller

Example of wiring a brake

Cables must be provided by the customer.

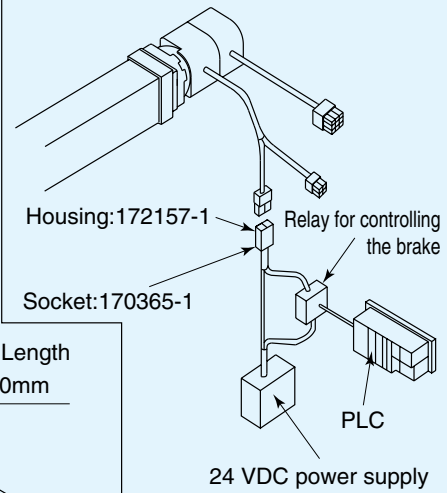

○ RS232C Cable
TH-RSC02
Option (2m)

● Controller QT

Supplied Controller is not a UL listed. For UL listed Controller, Please Contact THK.

Main Power Supply

24 VDC Power Supply
(0.4A)

PLC

PC

Shaded cables provided by the customer.

PLC, PC and a 24 VDC power supply provided by the customer.

“□” denotes actuator-related items; “◎” denotes cables; “●” denotes controller-related items; and “○” denotes an optional cable.

VLA-ST Type

●Part Number

VLA — ST — 45 — 06 — 0150 — D — 310 — I — R — N
 ① ② ③ ④ ⑤ ⑥ ⑦ ⑧ ⑨ ⑩

- | | | |
|---|--|--|
| ① Actuator Part Number
② Actuator Type: ST
③ Actuator Height
45: 45mm
60: 60mm
④ Ball Screw Lead
06: 6 mm
12: 12 mm
⑤ Stroke
Ex) 0050: 50 mm
0200: 200 mm | ⑥ Motor (Assembly)
D: Direct Assy
N: No Motor
S: Custom Motor
⑦ Motor Size
310: ST-45 30W-100V-No Brake
31B: ST-45 30W-100V-Brake*
510: ST-60 50W-100V-No Brake
51B: ST-60 50W-100V-Brake*
A10: ST-60 100W-100V-No Brake
A1B: ST-60 100W-100V-Brake*
000: No Motor
S00: Custom Motor | ⑧ Motor Encoder spec
I: Incremental Encoder
N: No Motor
S: Custom Motor
⑨ Motor Cable Orientation
U: Up
B: Bottom
R: Right
L: Left
N: No Motor
S: Custom Motor
⑩ Option
N: no option |
|---|--|--|

* Brake control cannot be performed with the QT controller. To control the brake, use the controller on the upper PLC side.

●VLA-ST Type Specifications

Items	Unit	ST-45 (30W)		ST-60 (50W)		ST-60 (100W)		
		High Vel.	Medium Vel.	High Vel.	Medium Vel.	High Vel.	Medium Vel.	
Continuous Velocity (note 1)	mm/s	600	300	600	300	600	300	
Max Velocity	mm/s	Stroke~300	1000	500	1000	500	1000	500
		Stroke 350	1000	500	800	400	800	400
		Stroke 400	1000	500	800	400	800	400
		Stroke 450	840	420	800	400	800	400
		Stroke 500	680	340	800	400	800	400
		Stroke 550			800	400	800	400
		Stroke 600			680	340	680	340
				500	250	500	250	
Continuous Force	N	40	80	67	133	134	267	
Max Force	N	117	235	201	402	398	796	
Max Acceleration	G	0.3						
Horizontal Payload	kg	5	10	8	16	16	30	
Vertical Payload	kg	1.5	3	2.5	5	5	10	
Ball Screw Shaft Dia.	mm	8		12				
Ball Screw Lead	mm	12	6	12	6	12	6	
Motor Wattage	W	30		50		100		
Motor Continuous Torque	N•m	0.095		0.159		0.319		
Motor Encoder Resolution	ppr	2000						
Repeatability	mm	±0.020						
Backlash	mm	0.1						
Permissible Moment	N•m	Ma=Mb=12 Mc=31		Ma=Mb=25.7 Mc=58				
Lifetime (note 2)	km	5000						

Note 1: The value applies when the actuator receives a load and operates at the rated speed and acceleration of 0.3 G

Note 2: The specifications apply to the actuator mounted with each size of a standard motor in page 13. If a different motor is used, the actuator's specifications are different. Also note that the rated values of the actuator unit must not be exceeded.

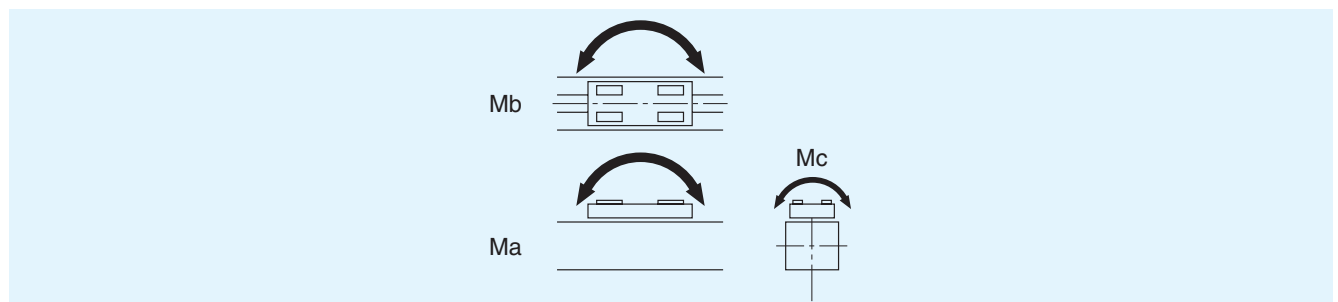

●VLA-ST-45 Outline Drawing

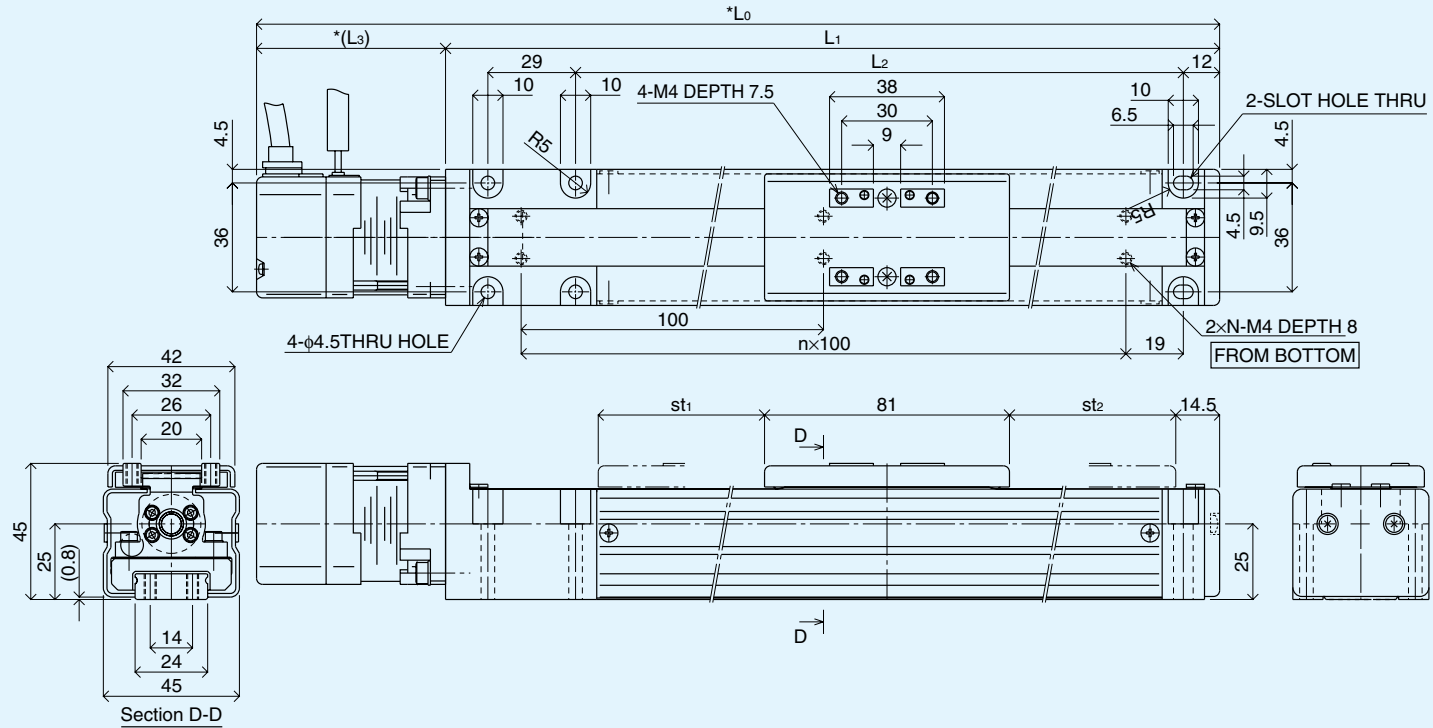

Dimensions

Unit: mm

Stroke	Effective Stroke	Stroke between stoppers st_1+st_2	L_0^{*1}	L_1	L_2	L_3^{*1}	n	N	Weight (kg) ^{*2}
0050	50	60	268.5(299.5)	206	151	62.5(93.5)	1	2	1.2(1.4)
0100	100	110	318.5(349.5)	256	201		2	3	1.3(1.5)
0150	150	160	368.5(399.5)	306	251		2	3	1.4(1.6)
0200	200	210	418.5(449.5)	356	301		3	4	1.5(1.7)
0250	250	260	468.5(499.5)	406	351		3	4	1.6(1.8)
0300	300	310	518.5(549.5)	456	401		4	5	1.7(1.9)
0350	350	360	568.5(599.5)	506	451		4	5	1.8(2.0)
0400	400	410	618.5(649.5)	556	501		5	6	1.9(2.1)
0450	450	460	668.5(699.5)	606	551		5	6	2.0(2.2)
0500	500	510	718.5(749.5)	656	601		6	7	2.2(2.4)

*1) Each value in the parentheses for L_0 and L_3 represents the dimension when a brake is attached.

*2) Each value in the parentheses represents the mass when a brake is attached.

●VLA-ST-60 Outline Drawing

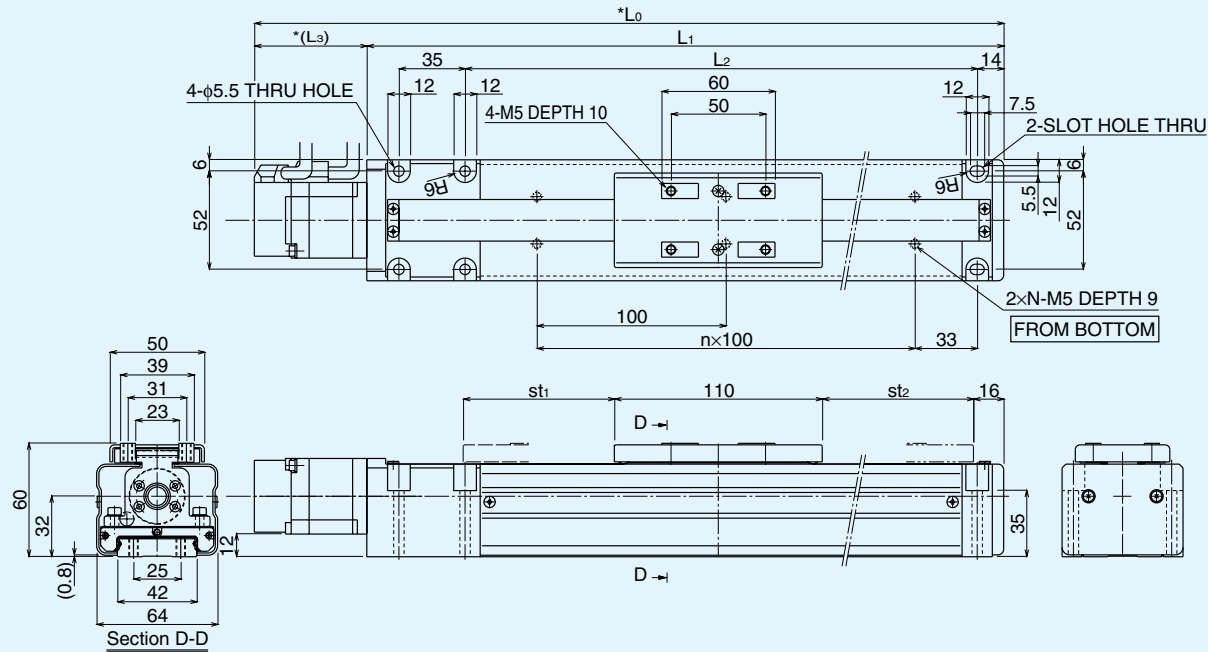

Dimensions

Unit: mm

Stroke	Effective Stroke	Stroke between stoppers st_1+st_2	$L_0^{*1)}$		L_1	L_2	$L_3^{*1)}$		n	N	Weight (kg) ^{*2)}	
			50W	100W			50W	100W			50W	100W
0050	50	60	296.5(332.1)	310.5(346.1)	237	171	59.5(95.1)	73.5(109.1)	1	2	2.3(2.5)	2.4(2.6)
0100	100	110	346.5(382.1)	360.5(396.1)	287	221			2	3	2.5(2.7)	2.6(2.8)
0150	150	160	396.5(432.1)	410.5(446.1)	337	271			2	3	2.7(2.9)	2.8(3.0)
0200	200	210	446.5(482.1)	460.5(496.1)	387	321			3	4	2.9(3.1)	3.0(3.2)
0250	250	260	496.5(532.1)	510.5(546.1)	437	371			3	4	3.1(3.3)	3.2(3.4)
0300	300	310	546.5(582.1)	560.5(596.1)	487	421			4	5	3.3(3.5)	3.4(3.6)
0350	350	360	596.5(632.1)	610.5(646.1)	537	471			4	5	3.5(3.7)	3.6(3.8)
0400	400	410	646.5(682.1)	660.5(696.1)	587	521			5	6	3.7(3.9)	3.8(4.0)
0450	450	460	696.5(732.1)	710.5(746.1)	637	571			5	6	3.9(4.1)	4.0(4.2)
0500	500	510	746.5(782.1)	760.5(796.1)	687	621			6	7	4.1(4.3)	4.2(4.4)
0550	550	560	796.5(832.1)	810.5(846.1)	737	671			6	7	4.3(4.5)	4.5(4.7)
0600	600	610	846.5(882.1)	860.5(896.1)	787	721			7	8	4.5(4.7)	4.7(4.9)
0700	700	710	946.5(982.1)	960.5(996.1)	887	821			8	9	4.9(5.1)	5.1(5.3)

*1) Each value in the parentheses for L_0 and L_3 represents the dimension when a brake is attached.

*2) Each value in the parentheses represents the mass when a brake is attached.

7 ● Motor Cable Orientation

ST Type

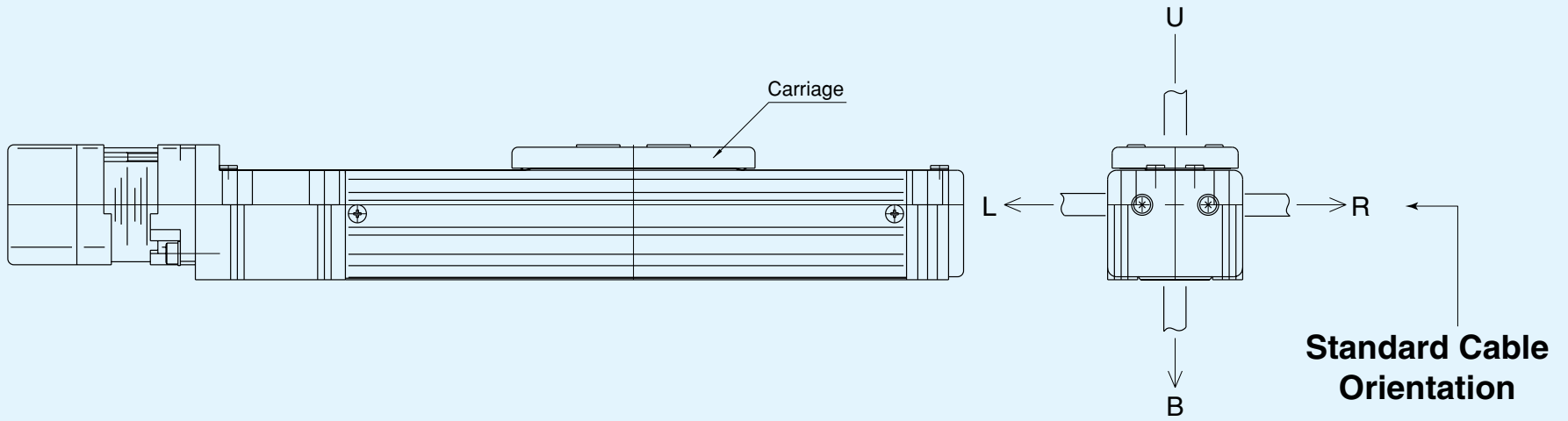

Model VLA-CT

Part Number

VLA — **CT** — **35** — **12** — **0150** — **D** — **310** — **I** — **U** — **A**
 ① ② ③ ④ ⑤ ⑥ ⑦ ⑧ ⑨ ⑩

① Actuator Part Number ② Actuator Type: CT ③ Actuator Width 35: 35-mm 45: 45-mm 55: 55-mm ④ Ball Screw Lead 12: 12 mm ⑤ Stroke Ex) 0050: 50 mm 0200: 200 mm	⑥ Motor Assembly D: Direct Drive Assy N: No Motor S: Custom Motor ⑦ Motor Size 310: CT-35 30W-100V-No Brake 31B: CT-35 30W-100V-Brake* 510: CT-45 50W-100V-No Brake 51B: CT-45 50W-100V-Brake* A10: CT-55 100W-100V-No Brake A1B: CT-55 100W-100V-Brake* 000: No Motor S00: Custom Motor	⑧ Motor Encoder spec I: Incremental Encoder N: No motor S: Custom Motor ⑨ Motor Cable Orientation U: Up B: Bottom R: Right L: Left N: No Motor S: Custom Motor ⑩ Option A: With Bracket Base B: With Flange N: No Option
---	--	--

* Brake control cannot be performed with the QT controller. To control the brake, use the controller on the upper PLC side.

VLA-CT Specifications

Item	Unit	CT-35 (30W)	CT-45 (50W)	CT-55 (100W)
Continuous Velocity (note 1)	mm/s	600	600	600 (470 with 300-stroke type)
Continuous Force	N	40	67	134
Max Force	N	120	201	402
Horizontal Payload (note 2, 3)	kg	4	7	25
Vertical Payload (note 3)	kg	1.9	3.1	6.5
Ball Screw Lead (note 4)	mm	12		
Repeatability	mm	±0.020		
Ball Screw Shaft Dia	mm	8		12
Motor Wattage	W	30	50	100
Motor Continuous Torque	N•m	0.095	0.158	0.318
Motor Encoder Resolution	ppr	2000		
Rod Dia	mm	φ16	φ20	φ25
Stroke	mm	50/100/150	50/100/150/200	50/100/150/200/250/300
Lifetime (note 5)	km	5000		

Note 1: With the 300-stroke type of CT55, the rated speed is 470 mm/s as calculated from the critical speed of the ball screw. If the stroke is shorter, the actuator can be operated at 1,000 mm/s at a maximum. However, the service life may be shortened.

Note 2: Model CT is capable of receiving only an axial load. The horizontal mass capacity is the value when an LM Guide is also used and no axial load is applied to the rod. When making a selection, take into account the sliding resistance of the LM Guide. For specific sliding resistances of LM Guides, see the general catalog.

Note 3: The values apply at acceleration of 0.3 G.

Note 4: The value applies when the actuator receives a load and operates at the rated speed and acceleration of 0.3 G.

Note 5: The specifications apply to the actuator mounted with each size of a standard motor in page 13. If a different motor is used, the actuator's specifications are different. Also note that the rated values of the actuator unit must not be exceeded.

6 ● **VLA-CT-35 Outline Drawing**

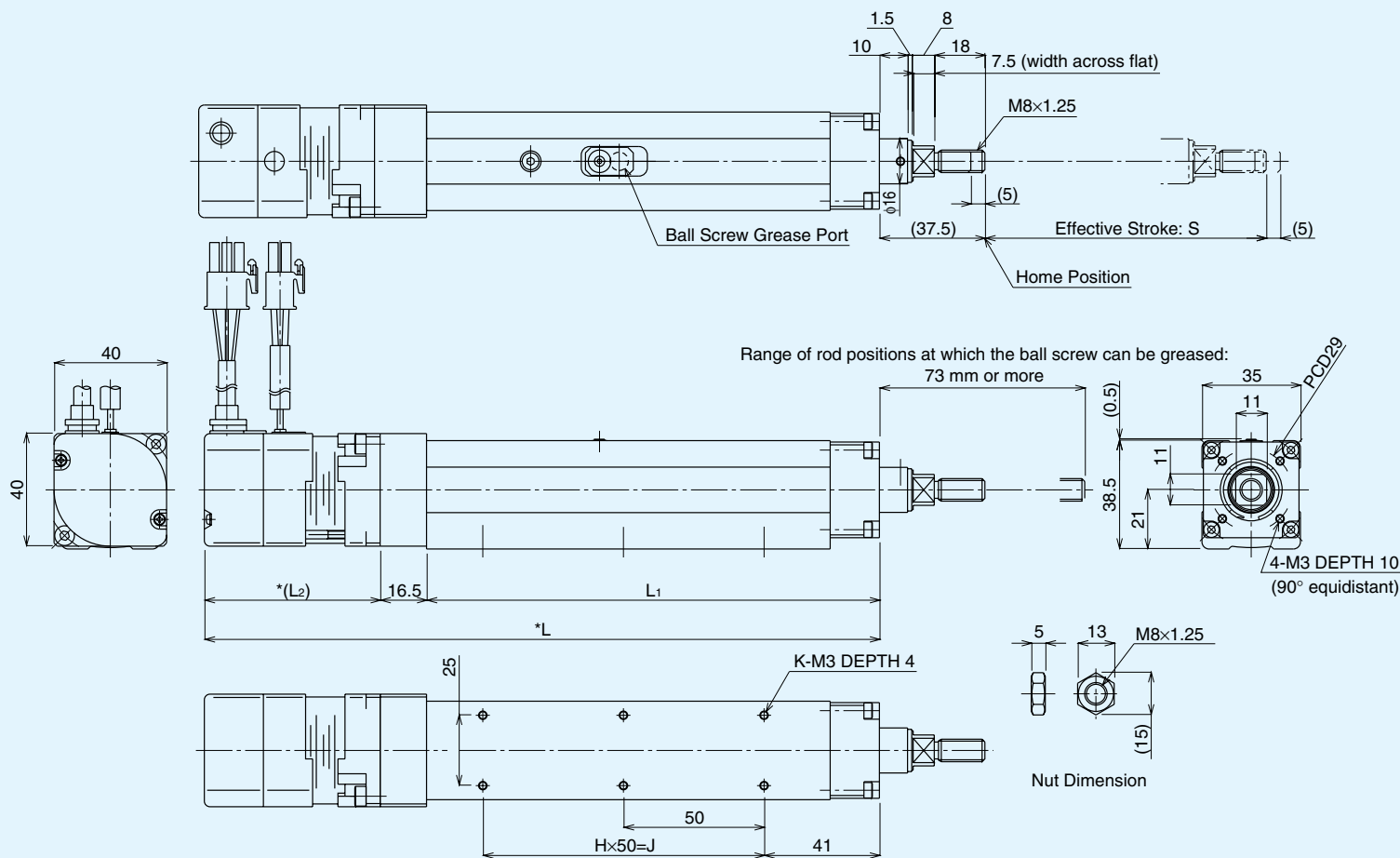

Dimensions

Unit: mm

Stroke	Effective Stroke: S	L ^{*1)}	L ₁	L ₂ ^{*1)}	H	J	K	Weight (kg) ^{*2)}
0050	50	240(271)	161	62.5(93.5)	2	100	6	1.0(1.2)
0100	100	290(321)	211		3	150	8	1.2(1.4)
0150	150	340(371)	261		4	200	10	1.3(1.5)

*1) Each value in the parentheses for L and L₂ represents the dimension when a brake is attached.

*2) Each value in the parentheses represents the mass when a brake is attached.

11 ● VLA-CT-55 Outline Drawing

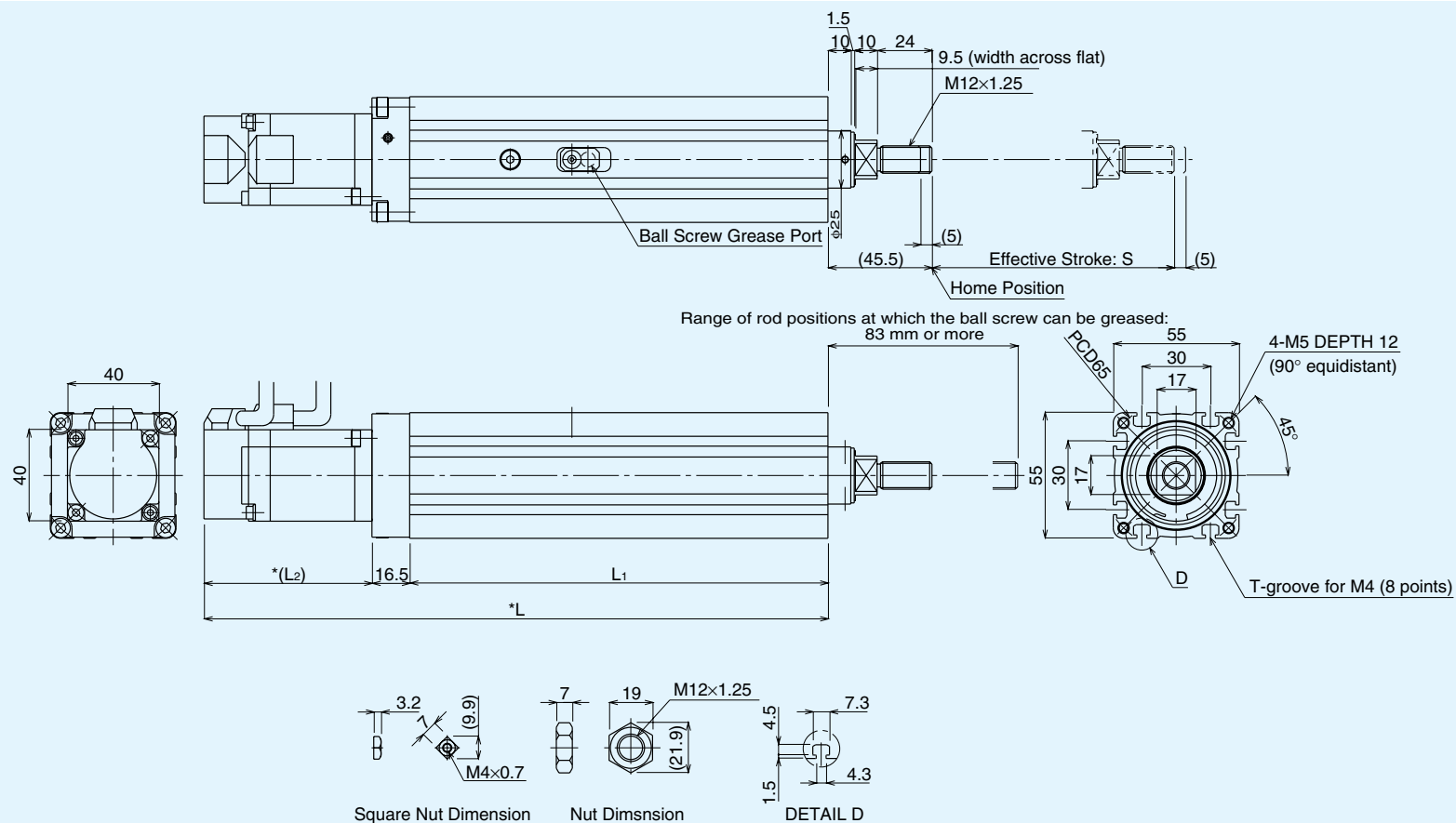

Dimensions

Unit: mm

Stroke	Effective Stroke: S	L ^{*1)}	L ₁	L ₂ ^{*1)}	Weight (kg) ^{*2)}
0050	50	273(308.6)	183	73.5(109.1)	2.2(2.4)
0100	100	323(358.6)	233		2.6(2.8)
0150	150	373(408.6)	283		3.0(3.2)
0200	200	423(458.6)	333		3.3(3.5)
0250	250	473(508.6)	383		3.7(3.9)
0300	300	523(558.6)	433		4.1(4.3)

*1) Each value in the parentheses for L and L₂ represents the dimension when a brake is attached.

*2) Each value in the parentheses represents the mass when a brake is attached.

●VLA-CT Options

Base Attachment Bracket

CT-35

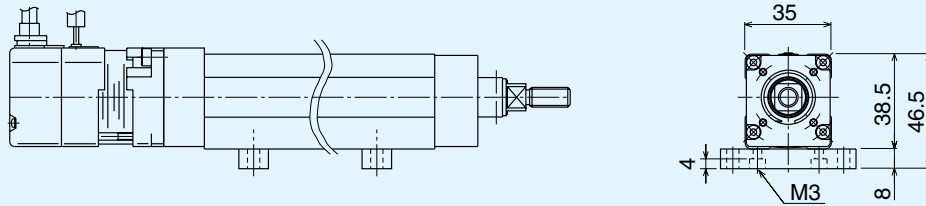
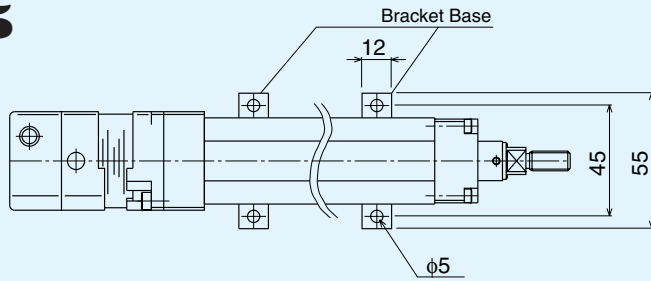

CT-45

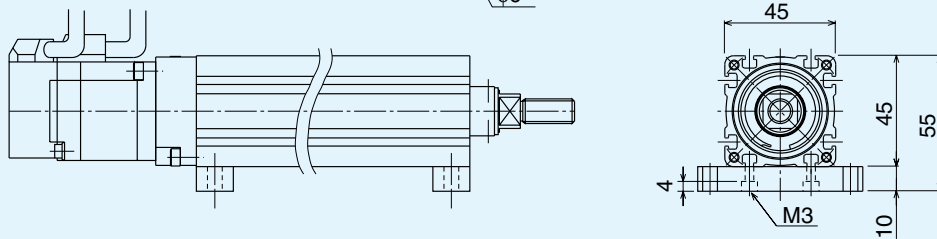
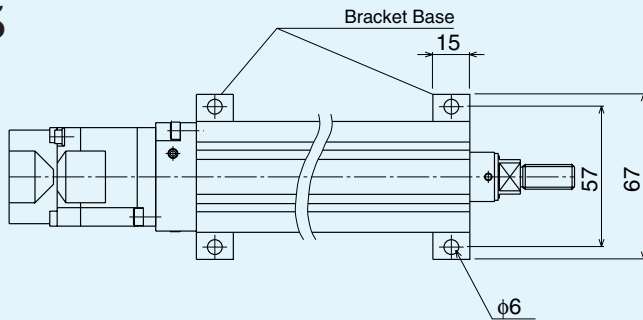

CT-45

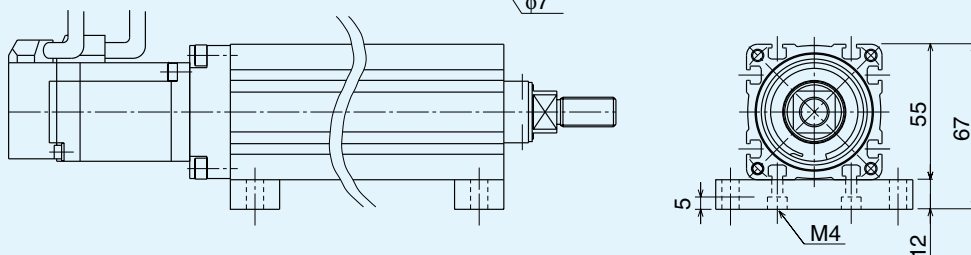
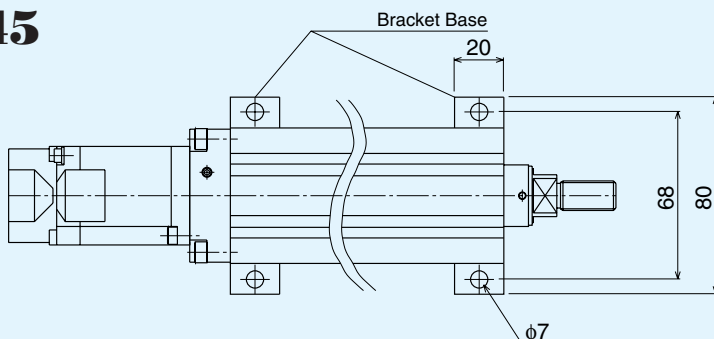

Bracket bases (option) are sold in pairs.

Flanges

CT-35

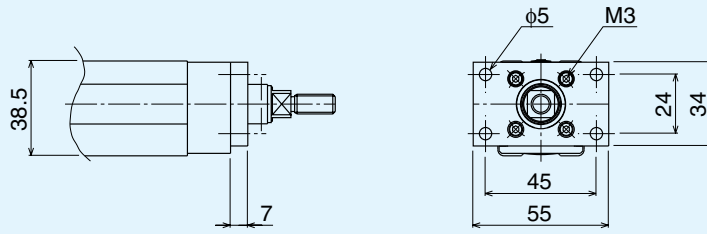
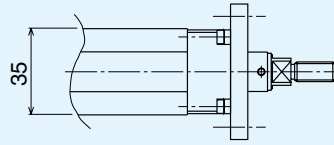

CT-45

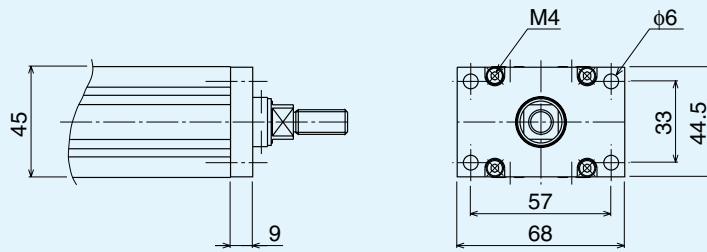
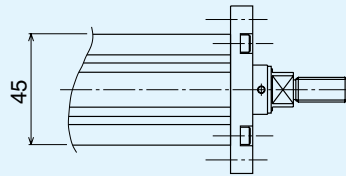

CT-45

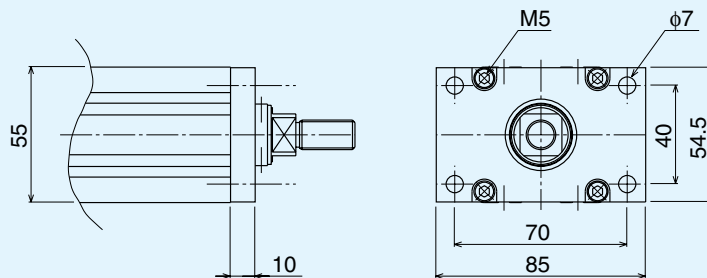
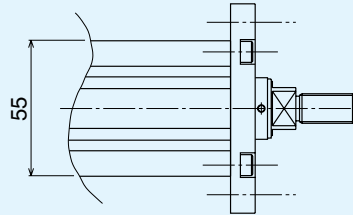

●Motor Cable Orientation

CT Type

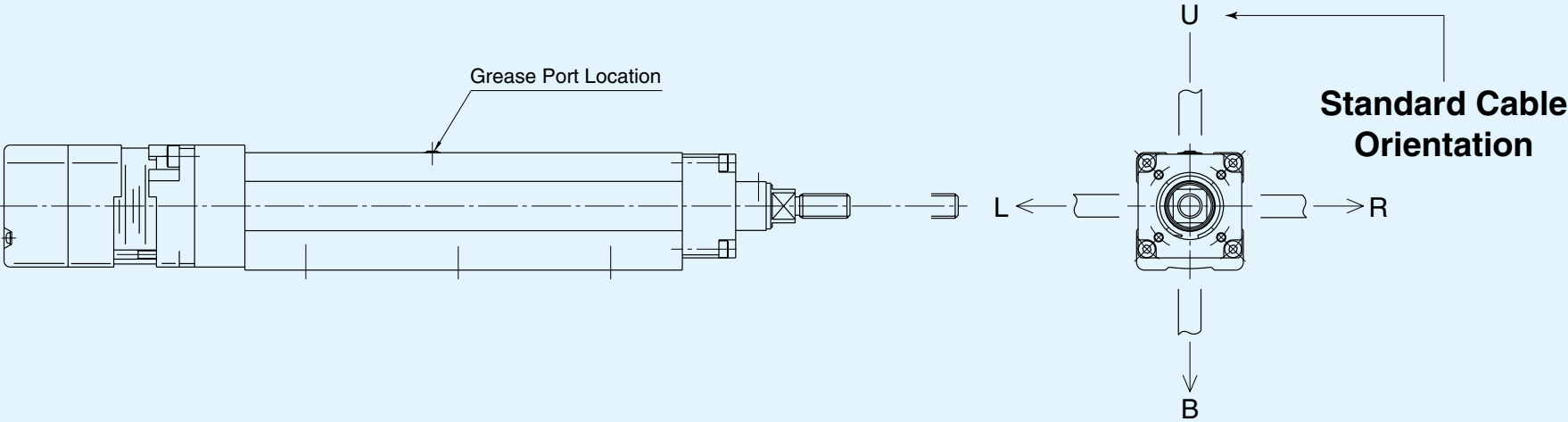

Type QT Controller

● Characteristics

- 1) Compact controller with a built-in driver with 32 bits RISC type CPU.
- 2) The memory capacity of 32 point positioning data received in from the digital operator or a computer. (Capable of numeric input and teaching)
- 3) When you input a starting signal by designating point number, it will move to the designated point. Therefore, it will feel like operating a pneumatic cylinder.

● Specifications

Controller type		QT-OP3TH1	QT-OP5TH1	QT-001TH1
Applicable Motor	Model	TS4501	TS4602	TS4603
Power supply	Rated output (W)	30W	50W	100W
	Rated input voltage	Single-phase, 100~110VAC, 50/60Hz		
	Allowable voltage fluctuation	10%		
	Power supply capacity	250VA	300VA	500VA
Control Method	Control method	Sinusoidal PWM control		
	Number of points	32 Points positioning		
	Acceleration/ Deceleration	S-Shaped curve and trapezoidal curve		
	Point command system	Point system		
Protective Functions	ROM Error			
	Overload			
	Encoder Error			
	Regenerative Error			
	Overheat			
	System Error			
	Excessive Deviation			
	Runaway			
	IGBT Error			
Other Functions	Multi-Function Input	Seven Input signal; Emergency Stop, JOG+, JOG-, Reset, Start, Start at Origin, HOLD		
	Multi-Function Output	Three (3) Output Signals; Servo is ready, Positioning is complete, Alarm		
	Designation of Point Input	Five (5) Binary Inputs		
	Display: Charge Indicator (LED) Digital Operator	Light indicator signifies controller charged Segment LED's (Mode, Data, +, -)		
	Terminals	Input power (TB1), Motor power terminal (TB2), I/O Connector, (CN2), Motor Encoder (CN1), RS232C to PC (CN4)		
	Wiring Distance between controller & motor	MAX 10m		
	Insulation Resistance/Ground	500VDC over 100M ohm/Type D ground		
Environmental Conditions	Ambient Temperature	0~40°C		
	Humidity	20~80% RH (non-condensing)		
	Transport/Storage Temperature	-10~60°C		
	Location	Free from corrosive 7 inflammable gases, oil, mist, dust		
	Elevation	1000meter (3300Ft)		
	Noise Resistance	1500V, No operation error allowed for 1 minute @ 1 micro s.		
	Vibration	0.5G		
Physical Characteristics	Enclosure	Open chassis (IP00)		
	Weight (kg)	0.8		
	Dimension	55(W), 160(H), 130(D)		
	Communications	Digital operator or PC via RS232C		

●Input/Output Circuit/Pin configuration

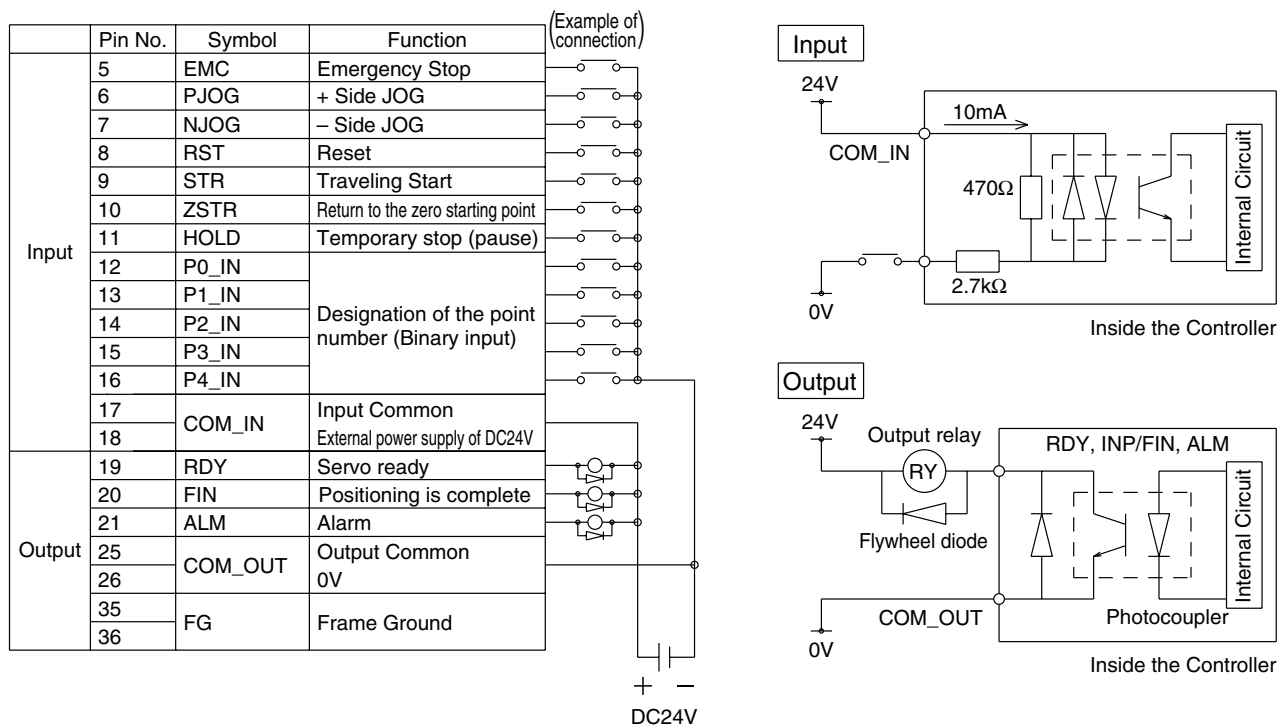

* Customer to provide 24VDC, 0.4A power supply.

* The logic of pin number 5(emergency stop) can be changed by the parameter.

●Exclusive PC Support tool for QT Type Controller (Items : QT-PC)

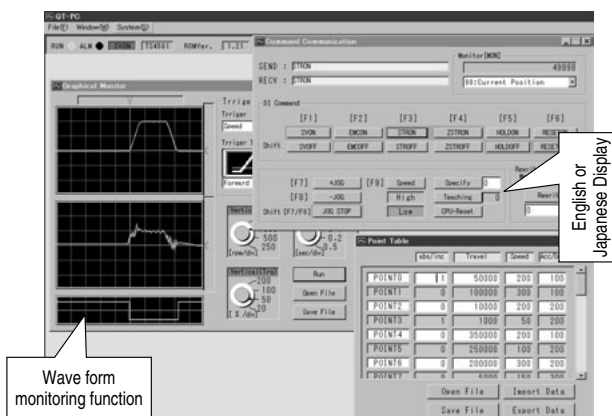

QT-PC Exclusive PC support tool allows you to

- Monitor speed, acceleration, and point data.
 - Set-up parameters.
 - Jog operation and point transfer.
 - Monitor speed wave-form, current wave-form and positioning full signal.
- Down load software from THK's web site

Web site <http://www.thk.com/>
THK technical support <http://www.lmsystem.com/>

●Outline Drawing

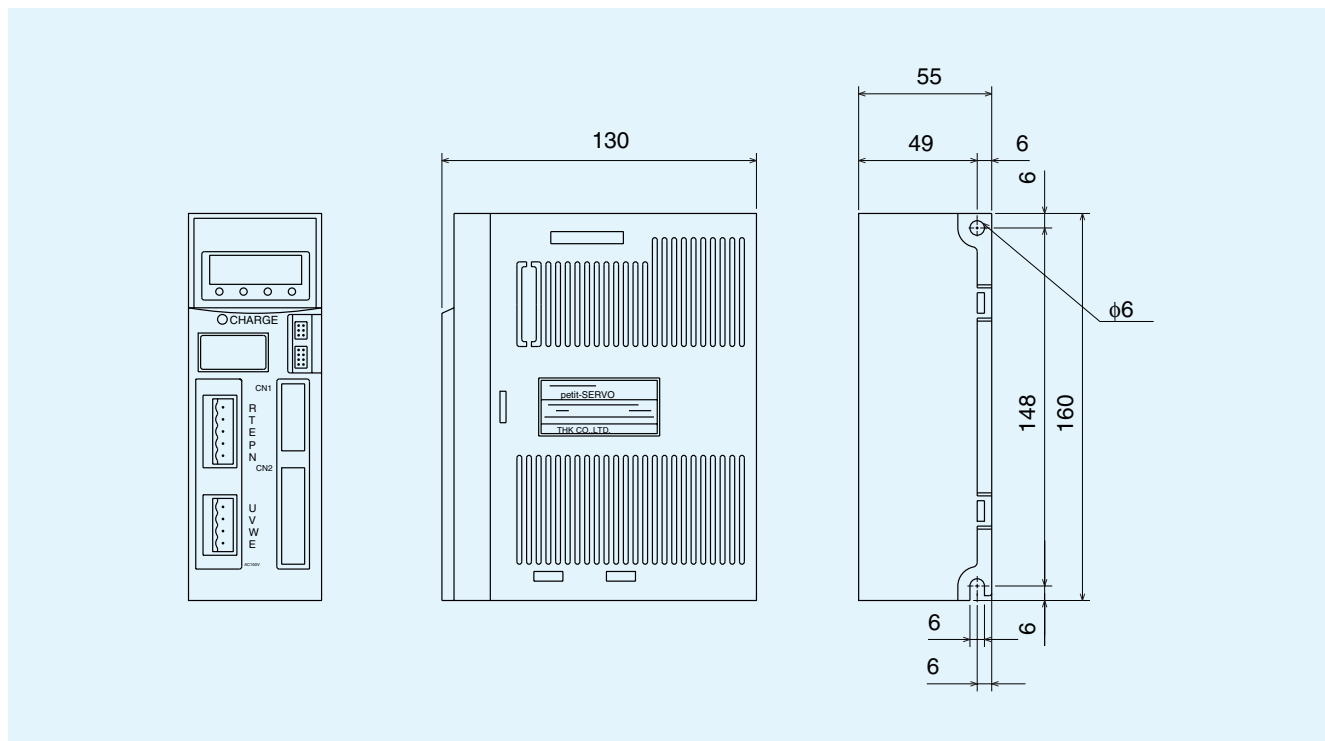

●Controller Model Number Designation

QT — 0 P3 TH1

① ② ③ ④

① Model	③ Motor Capacity P3: 30W for ST45 & CT35 P5: 50W for ST60 & CT45 01: 100W for ST60 & CT55	④ Input Method
② Encoder Spec. 0: 2000ppr		

●Cable Model Number Designation

TH — MCB 03

① ② ③

① Model	③ Cable Length 03: 3 meter (Standard Length) 05: 5 meter 07: 7 meter 10: 10meter 01: 1 meter (Only for RSC) 02: 2 meter (Only for RSC)
② Cable Type MCB: Motor Power Cable ECB: Motor Encoder Cable PWB: Power Cable with Ground RSC: RS232C Cable	

● Custom Motors

VLA type linear actuators are shipped with standard factory supplied motors. Alternate motors are available upon request. The list below offers THK approved motor suppliers. Motor model numbers do not reflect a flange bracket.

For detailed motor mounting dimensions, please refer to the outline drawings below.

Model No.		Applicable Actuator		
		ST Type	CT Type	
FANUC	βM0.2	ST-60	CT-45	
	βM0.3		CT-55	
YASKAWA	Σ-III	SGMAS-A5 SGMAS-01	CT-55	
				Σ-II
	Mitsubishi	HC-MFS053/HF-KP053	ST-60	
		HC-MFS13/HF-KP13	CT-55	
HC-KFS053		CT-45		
HC-KFS13		CT-55		
HC-PQ033		ST-45	CT-35	
HC-PQ053		CT-45		
HC-PQ13		ST-60	CT-55	
SANYO DENKI	P30B04003	ST-45		
	P30B04005	ST-60	CT-45	
	P30B04010	CT-55		
OMRON	R88M-W03030	ST-45		
	R88M-W05030	ST-60	CT-55	
	R88M-W10030			
	R88M-U03030	ST-45		
	R88M-U05030	ST-60	CT-55	
	R88M-U10030			

* For motor shaft, select a straight shaft.

* Customer to provide options and accessories for custom motors, such as, brakes, encoders, cables etc. Refer to the motor manufacturer's catalog to select options.

* Custom motors will be mounted by THK.

* If a custom motor is specified, actuator specification may change. The actuator is pre-set standard motor specifications. The actuator is not capable to operated beyond its rated preset conditions.

* Controller adjustments to be made by customer.

* No original point sensor is attached to the actuator. The use of an absolute encoder is recommended. Also, no OT sensor is available, use factory installed stopper/soft limit whenever necessary.

* With VLA-ST units with no motor mounted, no coupling attached. Customer to provide own coupling.

VLA-ST Type

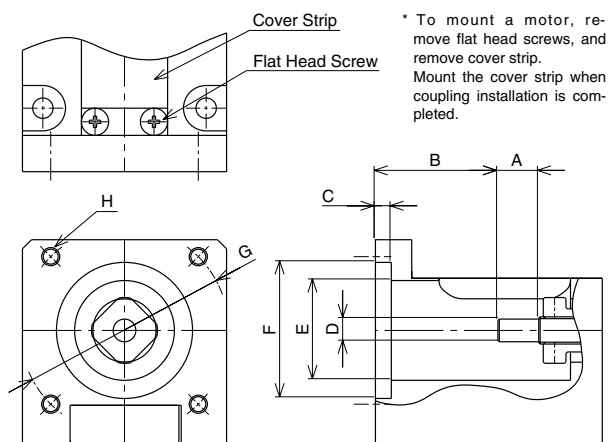

	A	B	C	D	E	F	G	H
ST-45	9	27	3.5	φ5	φ22	φ30	PCD46	4-M4, Depth 8
ST-60	8	30	3	φ6	φ28	φ30	PCD46	4-M4, Depth 8

VLA-CT Type

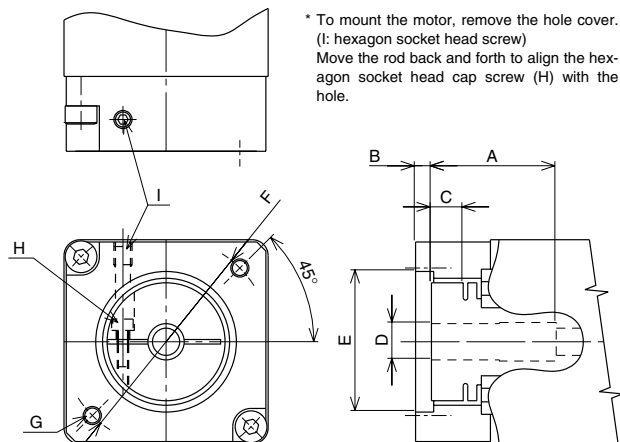

	A	B	C	D	E	F	G	H	I
CT-35	27.5	3.5	7	φ8	φ31	PCD46	2-M4, 12(D)	S.H.C.S. M2.5	Hex head screw M4x4L
CT-45	27.5	3.5	7	φ8	φ31	PCD46	2-M4, 12(D)	S.H.C.S. M2.5	Hex head screw M4x4L
CT-55	28.5	3.5	7	φ8	φ32	PCD46	4-M4, 12(D)	S.H.C.S. M2.5	Hex head screw M4x4L

THK Low Cost VLA Type Actuator

Precautions for Operation

● Handling

- Before starting operation of the Low Cost VLA type actuator, please read the contents of the product manual. Be sure to observe the handling warnings & precautions.
- Handle the unit carefully. Dropping or striking may cause damage to the unit.
- Do not disassemble the unit, Foreign materials may contaminate the unit causing malfunction or inaccuracy. Disassembly may be performed by qualified or authorized personnel and under emergency circumstances.

● Installation

Do not install the actuator and the controller if the following conditions exist:

- The ambient temperature is beyond 0 ~ 40°C range. The ambient humidity is beyond 20 ~ 80% RH range. If condensation exists.
- If inflammable gases are generated.
- Any dielectric powders such as iron powder, dust, and oil-mist, cutting fluid, moisture, sodium or organic solvent are generated or present in the atmosphere.
- If the unit is subject to direct sun or radiant heat.
- Intense electric field or ferromagnetic field is generated.
- Subject to excessive vibration or shock.
- If periodic maintenance, inspection or cleaning is not performed.

● Actuator Mounting Surface

- Mounting surface accuracy is to be equivalent or comparable (within 0.1mm) to the machined surface and the flatness of the actuators base.

● Instructions Manual

- You may download a digital file of the instruction manual of the VLA type actuator and also CAD files from THK's WEB site: www.thk.com

● Safety Precautions

- Do not touch the moving components of the actuator when the power is on.
- Do not step into the actuator operating area during operation,
- At the time of the installation, adjustment, inspection or maintenance of the actuator, the controller or the peripheral equipments, disconnect all electrical power supply sources. Observe local safety codes by installing locks and or displaying appropriate safety signs to prevent accidents. Be sure to observe all warnings and cautions outlined in the instruction manual. Provide necessary training to all personnel that will operate the unit.

● "LM Guide", "Ball Cage" and "QZ" are THK's registered trademarks.

● Contents of this catalog are subject to change without notice.

● THK takes no responsibility for damages resulting from errors or omissions in this catalog.

All rights reserved.

THK CO., LTD.

HEAD OFFICE 3-11-6, NISHI-GOTANDA, SHINAGAWA-KU, TOKYO 141-8503 JAPAN

ASIA PASEFIC SALES DEPARTMENT PHONE:(03)5434-0351 FAX:(03)5434-0353

NORTH AMERICA

CHICAGO

PHONE:(847)310-1111 FAX:(847)310-1182

NEW JERSEY

PHONE:(201)529-1950 FAX:(201)529-1962

ATLANTA

PHONE:(770)840-7990 FAX:(770)840-7897

LOS ANGELES

PHONE:(714)891-6752 FAX:(714)894-9315

SAN FRANCISCO

PHONE:(925)455-8948 FAX:(925)455-8965

BOSTON

PHONE:(781)575-1151 FAX:(781)575-9295

DETROIT

PHONE:(248)858-9330 FAX:(248)858-9455

TORONTO

PHONE:(905)712-2922 FAX:(905)712-2925

BRASIL (SÃO PAULO)

PHONE:(011)3767-0100 FAX:(011)3767-0101

EUROPE

DÜSSELDORF

PHONE:0049-(0)2102-7425-0 FAX:0049-(0)2102-7425-299

STUTTGART

PHONE:0049-(0)7150-9199-0 FAX:0049-(0)7150-9199-888

MÜNCHEN

PHONE:0049-(0)89-370616-0 FAX:0049-(0)89-370616-26

U.K.

PHONE:0044-(0)1908-303050 FAX:0044-(0)1908-303070

MILANO

PHONE:0039-039-2842079 FAX:0039-039-2842527

BOLOGNA

PHONE:0039-051-6412211 FAX:0039-051-6412230

SWEDEN

PHONE:0046-(0)8-4457630 FAX:0046-(0)8-4457639

AUSTRIA

PHONE:0043-(0)7229-51400 FAX:0043-(0)7229-51400-79

SPAIN

PHONE:0034-93-652-5740 FAX:0034-93-652-5746

THK FRANCE S. A. S.

PHONE:0033-(0)4-37491400 FAX:0033-(0)4-37491401

SOUTH AFRICA

PHONE:0027-(0)44-2720020 FAX:0027-(0)44-2720020

CHINA

THK SHANGHAI CO., LTD.

PHONE:(21)6334-5131 FAX:(21)6334-5137

BEIJING

PHONE:(10)6590-3559 FAX:(10)6590-3557

THK SHOUZAN CO., LTD.

PHONE:2376-1091 FAX:2376-0749

TAIWAN

TAIPEI

PHONE:(02)2888-3818 FAX:(02)2888-3819

TAICHUNG

PHONE:(04)2359-1505 FAX:(04)2359-1506

SOUTHERN

PHONE:(06)289-7668 FAX:(06)289-7669

KOREA (SEOUL)

PHONE:(02)3463-4351 FAX:(02)3468-4353

MALAYSIA (KUALA LUMPUR)

PHONE:(03)9287-1137 FAX:(03)9287-8071

INDIA (BANGALORE)

PHONE:(080)2330-1524 FAX:(080)2330-1524