







Unità di traslazione

Serie MX

Gamma

Unità di traslazione	Microslitta	<p>Serie MXU Guida lineare integrata Compattezza e flessibilità di montaggio e di connessione pneumatica.</p> 	<table border="1"> <thead> <tr> <th>Diam. tubo (mm)</th> <th colspan="6">Corse standard (mm)</th> </tr> <tr> <td></td> <td>5</td> <td>10</td> <td>15</td> <td>20</td> <td>25</td> <td>30</td> </tr> </thead> <tbody> <tr> <td>6</td> <td></td><td></td><td></td><td></td><td></td><td></td> </tr> <tr> <td>10</td> <td></td><td></td><td></td><td></td><td></td><td></td> </tr> <tr> <td>16</td> <td></td><td></td><td></td><td></td><td></td><td></td> </tr> </tbody> </table>	Diam. tubo (mm)	Corse standard (mm)							5	10	15	20	25	30	6							10							16							P.3.14-1																																																								
		Diam. tubo (mm)	Corse standard (mm)																																																																																												
		5	10	15	20	25	30																																																																																								
	6																																																																																														
	10																																																																																														
	16																																																																																														
	<p>Serie MXH Guida lineare Elevata rigidità grande precisione</p> 	<table border="1"> <thead> <tr> <th>Diam. tubo (mm)</th> <th colspan="8">Corse standard (mm)</th> </tr> <tr> <td></td> <td>5</td> <td>10</td> <td>15</td> <td>20</td> <td>25</td> <td>30</td> <td>40</td> <td>50</td> <td>60</td> </tr> </thead> <tbody> <tr> <td>6</td> <td></td><td></td><td></td><td></td><td></td><td></td><td></td><td></td><td></td> </tr> <tr> <td>10</td> <td></td><td></td><td></td><td></td><td></td><td></td><td></td><td></td><td></td> </tr> <tr> <td>16</td> <td></td><td></td><td></td><td></td><td></td><td></td><td></td><td></td><td></td> </tr> <tr> <td>20</td> <td></td><td></td><td></td><td></td><td></td><td></td><td></td><td></td><td></td> </tr> </tbody> </table>	Diam. tubo (mm)	Corse standard (mm)									5	10	15	20	25	30	40	50	60	6										10										16										20										P.3.15-1																																	
Diam. tubo (mm)	Corse standard (mm)																																																																																														
	5	10	15	20	25	30	40	50	60																																																																																						
6																																																																																															
10																																																																																															
16																																																																																															
20																																																																																															
<p>Serie MXS Guida lineare a rulli incrociati Ideale per montaggi di precisione</p> 	<table border="1"> <thead> <tr> <th>Diam. tubo (mm)</th> <th colspan="10">Corse standard (mm)</th> </tr> <tr> <td></td> <td>10</td> <td>20</td> <td>30</td> <td>40</td> <td>50</td> <td>75</td> <td>100</td> <td>125</td> <td>150</td> </tr> </thead> <tbody> <tr> <td>6</td> <td></td><td></td><td></td><td></td><td></td><td></td><td></td><td></td><td></td> </tr> <tr> <td>8</td> <td></td><td></td><td></td><td></td><td></td><td></td><td></td><td></td><td></td> </tr> <tr> <td>12</td> <td></td><td></td><td></td><td></td><td></td><td></td><td></td><td></td><td></td> </tr> <tr> <td>16</td> <td></td><td></td><td></td><td></td><td></td><td></td><td></td><td></td><td></td> </tr> <tr> <td>20</td> <td></td><td></td><td></td><td></td><td></td><td></td><td></td><td></td><td></td> </tr> <tr> <td>25</td> <td></td><td></td><td></td><td></td><td></td><td></td><td></td><td></td><td></td> </tr> </tbody> </table>	Diam. tubo (mm)	Corse standard (mm)											10	20	30	40	50	75	100	125	150	6										8										12										16										20										25										P.3.16-1												
Diam. tubo (mm)	Corse standard (mm)																																																																																														
	10	20	30	40	50	75	100	125	150																																																																																						
6																																																																																															
8																																																																																															
12																																																																																															
16																																																																																															
20																																																																																															
25																																																																																															
<p>Serie MXQ Guida a ricircolo di sfere Elevata resistenza ai carichi</p> 	<table border="1"> <thead> <tr> <th>Diam. tubo (mm)</th> <th colspan="8">Corse standard (mm)</th> </tr> <tr> <td></td> <td>10</td> <td>20</td> <td>30</td> <td>40</td> <td>50</td> <td>75</td> <td>100</td> <td>125</td> <td>150</td> </tr> </thead> <tbody> <tr> <td>6</td> <td></td><td></td><td></td><td></td><td></td><td></td><td></td><td></td><td></td> </tr> <tr> <td>8</td> <td></td><td></td><td></td><td></td><td></td><td></td><td></td><td></td><td></td> </tr> <tr> <td>12</td> <td></td><td></td><td></td><td></td><td></td><td></td><td></td><td></td><td></td> </tr> <tr> <td>16</td> <td></td><td></td><td></td><td></td><td></td><td></td><td></td><td></td><td></td> </tr> <tr> <td>20</td> <td></td><td></td><td></td><td></td><td></td><td></td><td></td><td></td><td></td> </tr> <tr> <td>25</td> <td></td><td></td><td></td><td></td><td></td><td></td><td></td><td></td><td></td> </tr> </tbody> </table>	Diam. tubo (mm)	Corse standard (mm)									10	20	30	40	50	75	100	125	150	6										8										12										16										20										25										P.3.17-1														
Diam. tubo (mm)	Corse standard (mm)																																																																																														
	10	20	30	40	50	75	100	125	150																																																																																						
6																																																																																															
8																																																																																															
12																																																																																															
16																																																																																															
20																																																																																															
25																																																																																															
<p>Serie MXF Guida lineare a rulli incrociati Unità di traslazione a profilo piatto</p> 	<table border="1"> <thead> <tr> <th>Diam. tubo (mm)</th> <th colspan="5">Corse standard (mm)</th> </tr> <tr> <td></td> <td>10</td> <td>20</td> <td>30</td> <td>50</td> <td>100</td> </tr> </thead> <tbody> <tr> <td>8</td> <td></td><td></td><td></td><td></td><td></td> </tr> <tr> <td>12</td> <td></td><td></td><td></td><td></td><td></td> </tr> <tr> <td>16</td> <td></td><td></td><td></td><td></td><td></td> </tr> <tr> <td>20</td> <td></td><td></td><td></td><td></td><td></td> </tr> </tbody> </table>	Diam. tubo (mm)	Corse standard (mm)						10	20	30	50	100	8						12						16						20						P.3.18-1																																																									
Diam. tubo (mm)	Corse standard (mm)																																																																																														
	10	20	30	50	100																																																																																										
8																																																																																															
12																																																																																															
16																																																																																															
20																																																																																															
<p>Serie MXW Guida a ricircolo di sfere Disponibili corse lunghe</p> 	<table border="1"> <thead> <tr> <th>Diam. tubo (mm)</th> <th colspan="14">Corse standard (mm)</th> </tr> <tr> <td></td> <td>25</td> <td>50</td> <td>75</td> <td>100</td> <td>125</td> <td>150</td> <td>175</td> <td>200</td> <td>225</td> <td>250</td> <td>275</td> <td>300</td> </tr> </thead> <tbody> <tr> <td>8</td> <td></td><td></td><td></td><td></td><td></td><td></td><td></td><td></td><td></td><td></td><td></td><td></td> </tr> <tr> <td>12</td> <td></td><td></td><td></td><td></td><td></td><td></td><td></td><td></td><td></td><td></td><td></td><td></td> </tr> <tr> <td>16</td> <td></td><td></td><td></td><td></td><td></td><td></td><td></td><td></td><td></td><td></td><td></td><td></td> </tr> <tr> <td>20</td> <td></td><td></td><td></td><td></td><td></td><td></td><td></td><td></td><td></td><td></td><td></td><td></td> </tr> <tr> <td>25</td> <td></td><td></td><td></td><td></td><td></td><td></td><td></td><td></td><td></td><td></td><td></td><td></td> </tr> </tbody> </table>	Diam. tubo (mm)	Corse standard (mm)															25	50	75	100	125	150	175	200	225	250	275	300	8													12													16													20													25													P.3.19-1
Diam. tubo (mm)	Corse standard (mm)																																																																																														
	25	50	75	100	125	150	175	200	225	250	275	300																																																																																			
8																																																																																															
12																																																																																															
16																																																																																															
20																																																																																															
25																																																																																															
<p>Serie MXP Guida lineare Unità di traslazione ad alta precisione</p> 	<table border="1"> <thead> <tr> <th>Diam. tubo (mm)</th> <th colspan="5">Corse standard (mm)</th> </tr> <tr> <td></td> <td>5</td> <td>10</td> <td>15</td> <td>20</td> <td>25</td> <td>30</td> </tr> </thead> <tbody> <tr> <td>6</td> <td></td><td></td><td></td><td></td><td></td><td></td> </tr> <tr> <td>10</td> <td></td><td></td><td></td><td></td><td></td><td></td> </tr> <tr> <td>12</td> <td></td><td></td><td></td><td></td><td></td><td></td> </tr> <tr> <td>16</td> <td></td><td></td><td></td><td></td><td></td><td></td> </tr> </tbody> </table>	Diam. tubo (mm)	Corse standard (mm)						5	10	15	20	25	30	6							10							12							16							P.3.20-1																																																				
Diam. tubo (mm)	Corse standard (mm)																																																																																														
	5	10	15	20	25	30																																																																																									
6																																																																																															
10																																																																																															
12																																																																																															
16																																																																																															

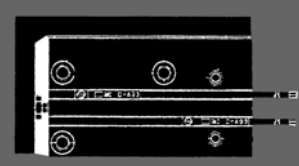

Microslitta pneumatica Serie MXU

ø6, ø10, ø16

La guida lineare integrata migliora la precisione del movimento lineare e antirotante

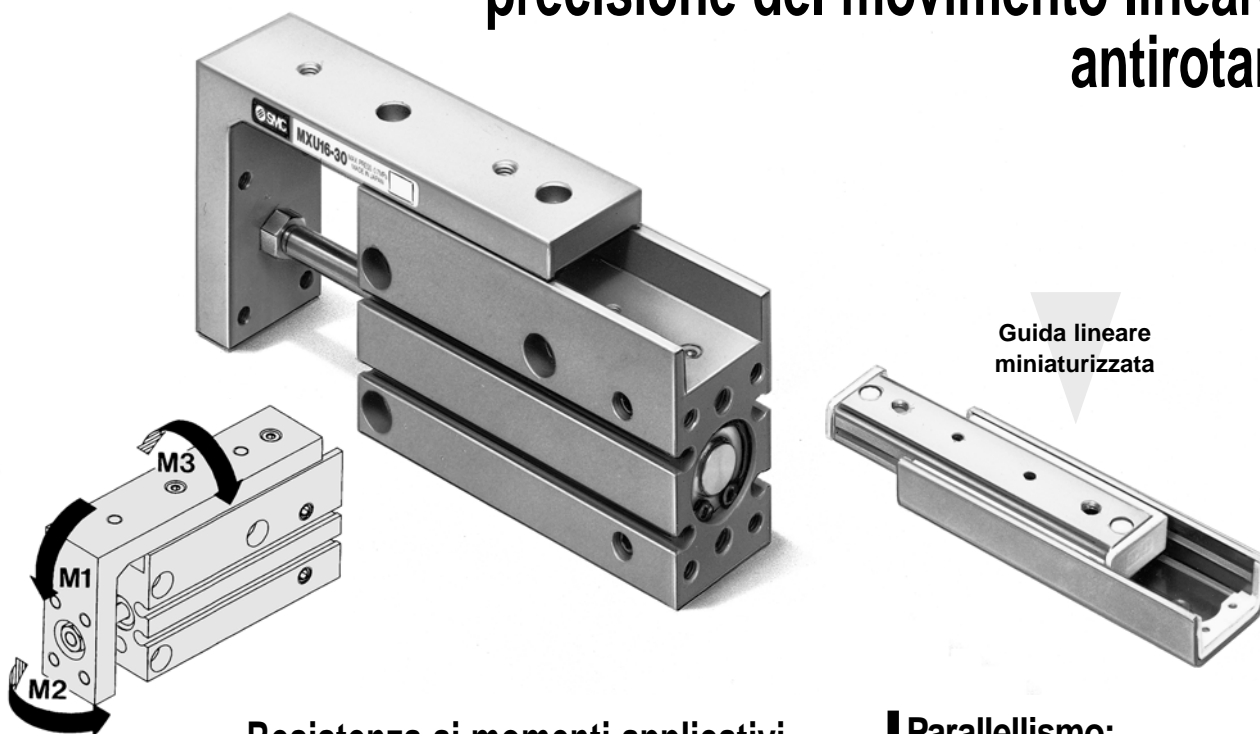

Resistenza ai momenti applicativi

- Scostamento lineare della tavola
 - Scostamento angolare della tavola
- M1** (momento flettente): $\leq 0.02\text{mm}$
- M2** (momento flettente): $\leq 0.01\text{mm}$
- M3** (momento torcente): $\leq 0.25^\circ$

Parallellismo:
 $\leq 0,05\text{mm}$

Possibilità
montaggio sensore

Possibilità di mon-
taggio su 3 lati

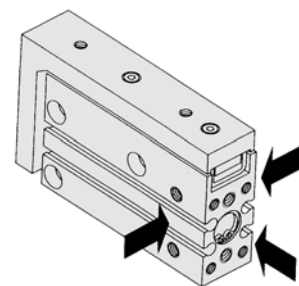

Montaggio universale

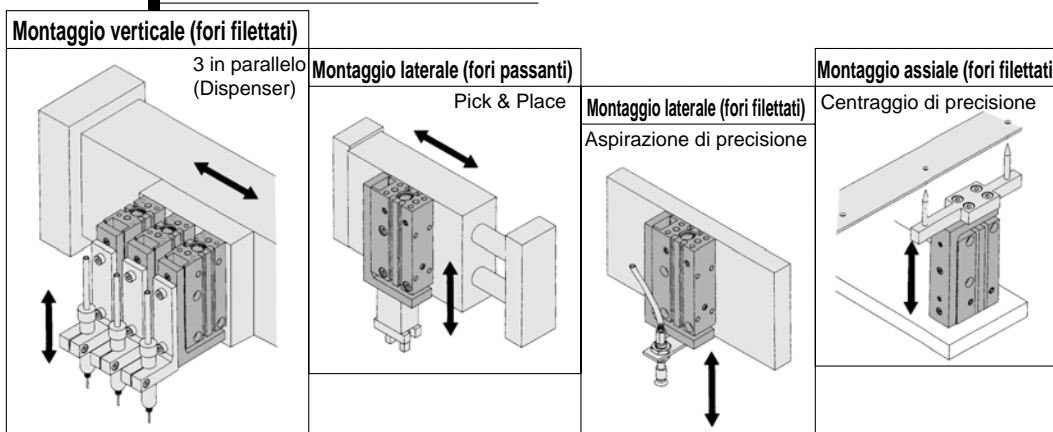

Microslitta pneumatica

Serie MXU

Codici d'ordinazione

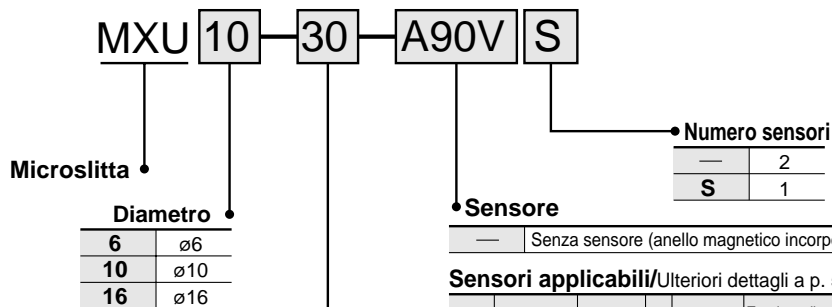

Sensori applicabili/ Ulteriori dettagli a p. 5.3-2.

Esec.	Funzione	Conness. elettrica	LED	Uscita	Tensione di carico		Tipo di sensore		Lunghezza cavi *			Applicazioni		
					cc	ca	Perpendicolare	In linea	0.5 (-)	3 (L)	5 (Z)	Circuito IC	Relè PLC	
Sensori reed	—	Grommet	No	2 fili	24V	5V	A90V	A90	●	●	—	Circuito IC	Relè PLC	
						≤100V			●	●	—			
Sensori stato solido	Indicatore di diagnostica (LED bicolore)	Grommet	Si	3 fili (NPN)	24V	12V	A93V	A93	●	●	—	Circuito IC	—	
									5V	●	●			—
				3 fili (PNP)	24V	12V	M9NV	M9N	●	●	—	Relè PLC		
									M9PV	M9P	●		●	—
									M9BV	M9B	●		●	—
									M9NWV	M9NW	●		●	○
3 fili (PNP)	24V	12V	M9PWV	M9PW	●	●	○							
2 fili			M9BWV	M9BW	●	●	○							

* Lunghezza cavi 0.5m: - es.) A93

3m: L es.) A93L

5m: Z es.) M9NWZ

* I sensori allo stato solido indicati con "○" si realizzano su richiesta.



Dati tecnici

Diametro cilindro (mm)	6	10	16
Fluido	Aria		
Funzione	Doppio effetto		
Attacco	M5		
Max. pressione d'esercizio	0.7MPa		
Pressione di prova	1.05MPa		
Temperatura d'esercizio	Senza sensore -10÷+70°C Con sensore -10÷+60°C		
Velocità	50÷500mm/sec		
Lubrificazione	Senza lubrificazione		
Ammortizzo	Paracolpi elastici su entrambi i lati		
Tolleranza sulla corsa	+1.0 0		
Sensore (opzione)	Sensori reed Sensori allo stato solido (2 fili, 3 fili)		

Min. pressione d'esercizio (MPa)

Diametro cilindro (mm)	6	10	16
Min. pressione d'esercizio	0.12	0.06	0.06

Tabella forza teorica (N)

Diametro (mm)	Campo d'esercizio	Pressione d'esercizio (MPa)		
		0.3	0.5	0.7
6	IN	6	11	15
	OUT	8	14	20
10	IN	20	33	46
	OUT	24	39	55
16	IN	52	86	121
	OUT	60	101	141

Corse standard

Diametro (mm)	Corsa standard (mm)
6, 10, 16	5, 10, 15, 20, 25, 30

* Vedere corsa minima per montaggio sensori a p.3.14-10.

Peso (g)

Modello	Corsa cilindro (mm)					
	5	10	15	20	25	30
MXU6	66	72	81	88	97	103
MXU10	115	124	138	147	166	174
MXU16	216	215	251	250	285	300

Carico massimo

Peso (g)

Modello	Max. carico
MXU6	100
MXU10	200
MXU16	400

Momento ammissibile

Modello	Campo di corsa	Momento ammissibile (Nm)			Quote fisse (mm)	
		M1	M2	M3	Cp/Cy	Cr
MXU6	5	0.046	0.040	0.049	28.3	7.5
	10	0.046	0.040	0.049	28.3	
	15	0.061	0.053	0.062	31.5	
	20	0.061	0.053	0.062	34	
	25	0.076	0.066	0.074	38.5	
	30	0.076	0.066	0.074	41	
MXU10	5	0.047	0.041	0.109	28.5	9.5
	10	0.047	0.041	0.109	31	
	15	0.080	0.069	0.169	36	
	20	0.080	0.069	0.169	38.5	
	25	0.103	0.089	0.212	44	
	30	0.103	0.089	0.212	46	
MXU16	5	0.115	0.099	0.296	37.5	12
	10	0.115	0.099	0.296	37.5	
	15	0.153	0.132	0.380	46	
	20	0.153	0.132	0.380	46	
	25	0.190	0.165	0.464	50	
	30	0.190	0.165	0.464	52.5	

Avvertenze

Leggere attentamente prima dell'uso. Vedere istruzioni di sicurezza e precauzioni comuni da p.0-39 a 0-43.

⚠ Precauzione

- ① Non introdurre le dita nello spazio tra tavola e tubo poiché potrebbero rimanere incastrate allorché lo stelo rientra. Il cilindro sviluppa una grande forza e i danni sarebbero notevoli.
- ② Il cilindro deve operare non oltre il carico e il momento ammissibili.
- ③ Se l'azione della microslitta viene applicata direttamente alla tavola, si raccomanda che ciò venga realizzato lungo l'asse dello stelo. (Vedere figura sotto)

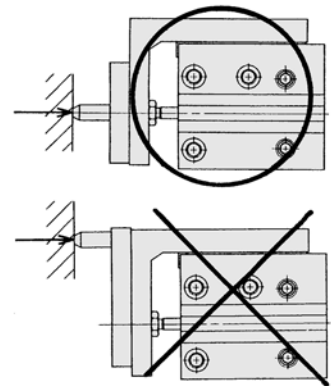

- ④ Installare un regolatore di flusso tarato a $\leq 500\text{mm/s}$.

Calcolo delle forze ammissibili F_p , F_y , F_r

F_p	F_y	F_r
$F_p = \frac{M1 \times 1000}{L_p + C_p + (St/2)} \text{ (N)}$ <p>Lp: Distanza della tavola dall'asse del carico (mm) Cp: Quota da tabella (mm) St: Corsa (mm)</p>	$F_y = \frac{M2 \times 1000}{L_y + C_y + (St/2)} \text{ (N)}$ <p>Ly: Distanza della tavola dall'asse del carico (mm) Cy: Quota da tabella (mm) St: Corsa (mm)</p>	$F_r = \frac{M3 \times 1000}{L_r + C_r} \text{ (N)}$ <p>Lr: Distanza della tavola dall'asse del carico (mm) Cr: Quota da tabella (mm)</p>

Serie MXU

Montaggio microslitta

Possibilità di montaggio in 4 posizioni, a seconda delle proprie esigenze.

Montaggio laterale (fori passanti)

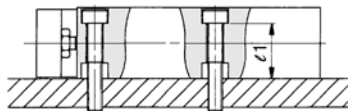

Modello	Bullone	Max. coppia di serraggio	ℓ 1
MXU6	M3	1.1	12.7
MXU10	M4	2.5	15.6
MXU16	M4	2.5	20.6

Montaggio laterale (fori filettati)

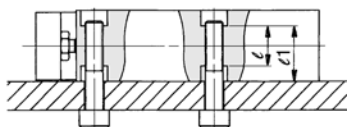

Modello	Bullone	Max. coppia di serraggio	ℓ 1	ℓ
MXU6	M4	2.5	12.7	9.4
MXU10	M5	5.1	15.6	11.2
MXU16	M5	5.1	20.6	16.2

Montaggio verticale (fori filettati)

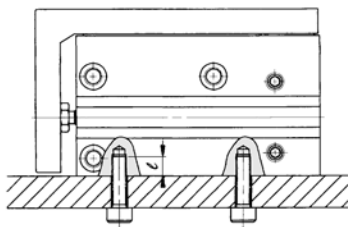

Modello	Bullone	Max. coppia di serraggio	ℓ
MXU6	M3	1.1	4.8
MXU10	M4	2.5	6
MXU16	M4	2.5	6

Montaggio assiale (fori filettati)

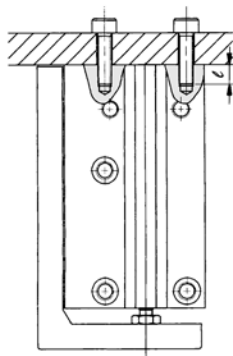

Modello	Bullone	Max. coppia di serraggio	ℓ
MXU6	M3	1.1	4.8
MXU10	M4	2.5	6
MXU16	M4	2.5	6

Montaggio del carico

Il carico può essere montato su due lati della microslitta.

- La tavola è sostenuta da una guida lineare miniaturizzata, non fissare il carico con forti impatti o momenti eccessivi.
- Fissare il carico tenendo ferma la tavola e non il corpo altrimenti potrebbero prodursi momenti superiori a quelli ammissibili, che diminuirebbero la precisione.

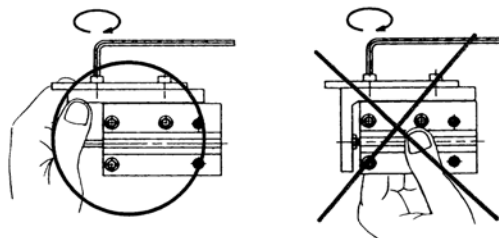

- Selezionare la miglior connessione con il carico mantenendo un meccanismo di guida e sostegno sull'esterno. L'allineamento dovrebbe essere completato.
- Graffi o scalfiture sullo stelo possono causare funzionamenti difettosi e trafileamenti d'aria

Flangia

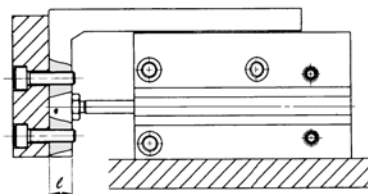

Modello	Bullone	Max. coppia di serraggio	ℓ
MXU6	M3	1.1	5
MXU10	M4	2.5	7
MXU16	M4	2.5	9.5

Montaggio frontale dall'alto

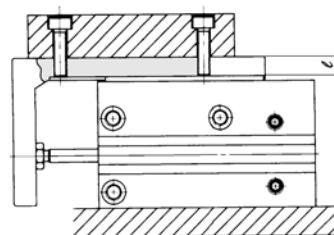

Modello	Bullone	Max. coppia di serraggio	ℓ
MXU6	M3	1.1	5
MXU10	M4	2.5	6
MXU16	M4	2.5	6

Direzione d'esercizio degli attacchi

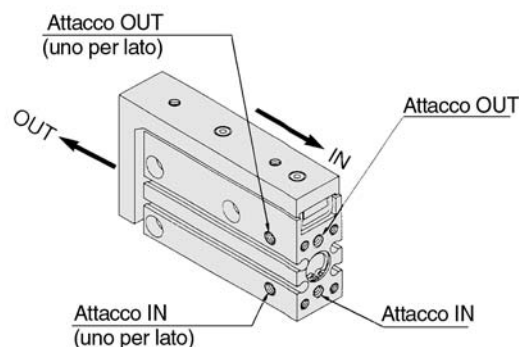

Dimensioni MXU **6** (ø6)

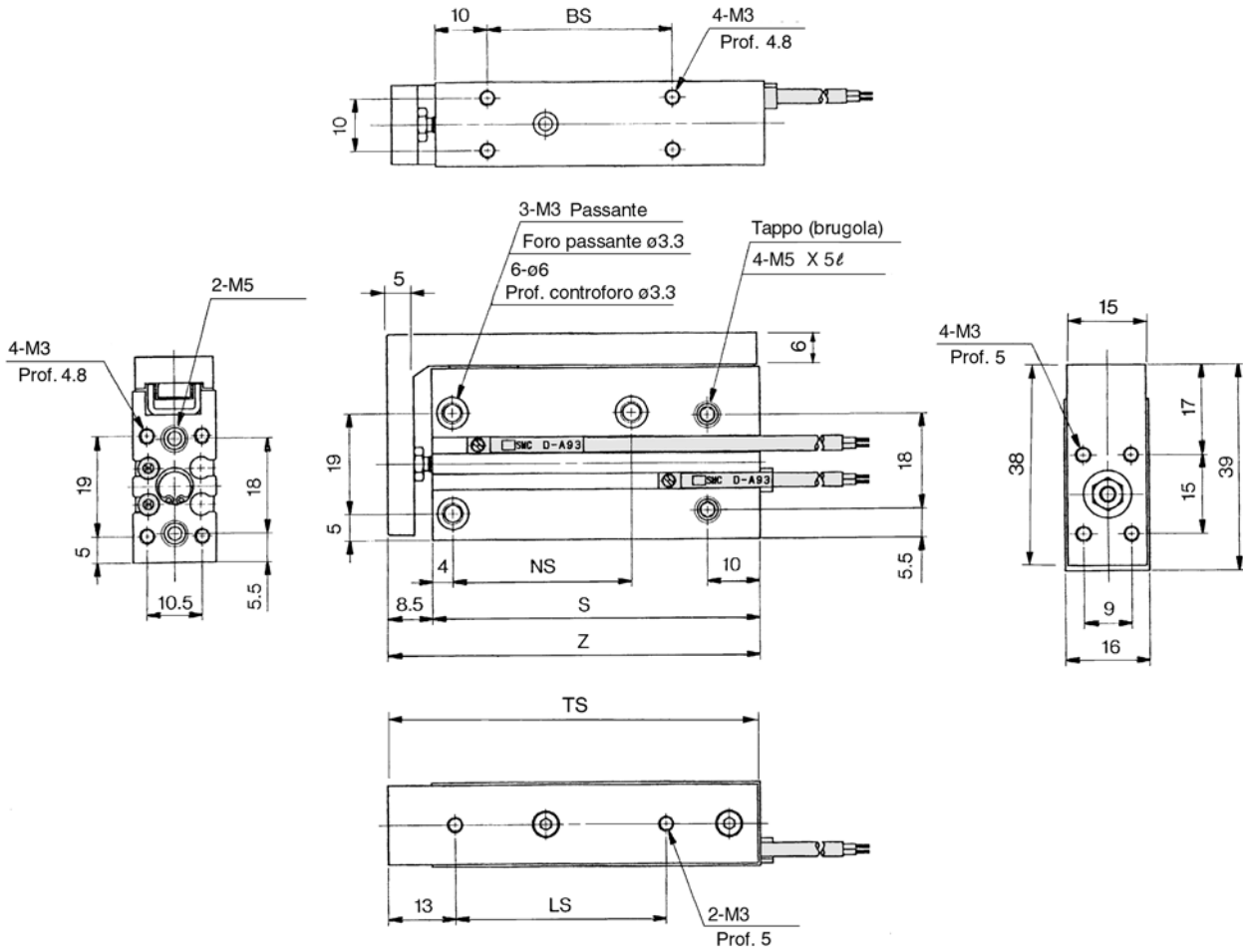

Corsa (mm)	BS	LS	NS	S	Z	TS
5	10	20	14	37.5	46	45.5
10	15	20	14	42.5	51	50.5
15	20	25	24	47.5	56	55.5
20	25	30	24	52.5	61	60.5
25	30	40	34	57.5	66	65.5
30	35	40	34	62.5	71	70.5

Serie MXU

MXU 10_(ø10)

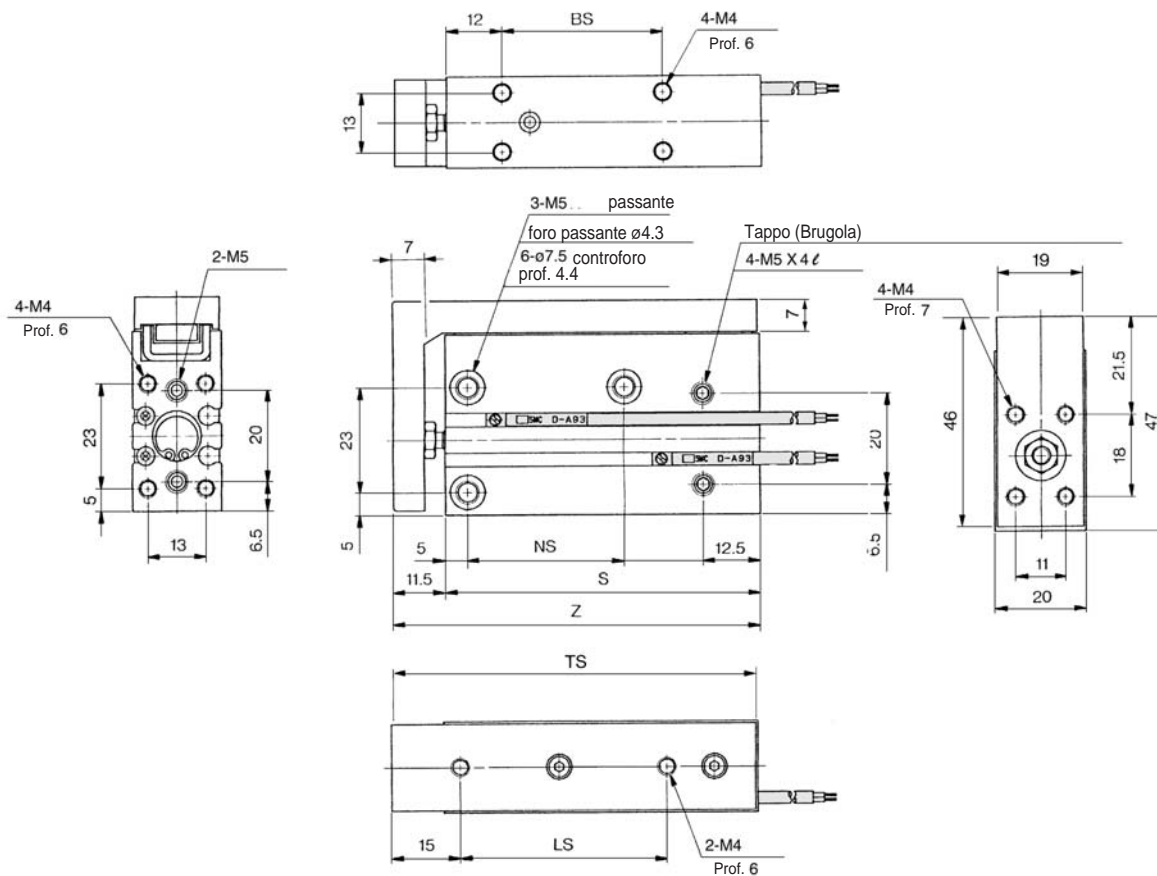

Corsa (mm)	BS	LS	NS	S	Z	TS
5	10	14	14	41.5	53	52.5
10	14	19	14	46.5	58	57.5
15	18	25	24	51.5	63	62.5
20	24	30	24	56.5	68	67.5
25	32	40	34	64.5	76	75.5
30	35	45	34	68.5	80	79.5

Dimensioni MXU **16** (ø16)

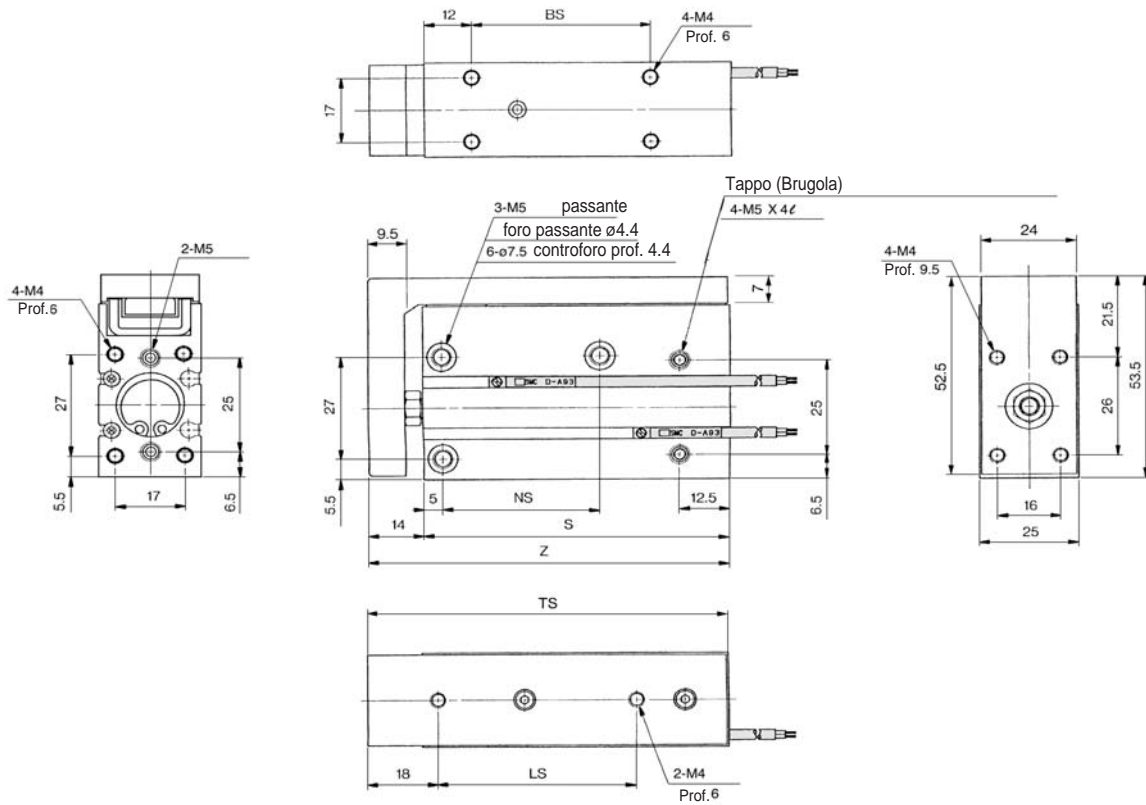

Corsa (mm)	BS	LS	NS	S	Z	TS
5	20	24	24	52	66	65.5
10	20	24	24	52	66	65.5
15	30	35	34	62	76	75.5
20	30	35	34	62	76	75.5
25	40	45	40	72	86	85.5
30	45	50	40	77	91	90.5

Serie MXU

Costruzione

MXU6 (ø6)

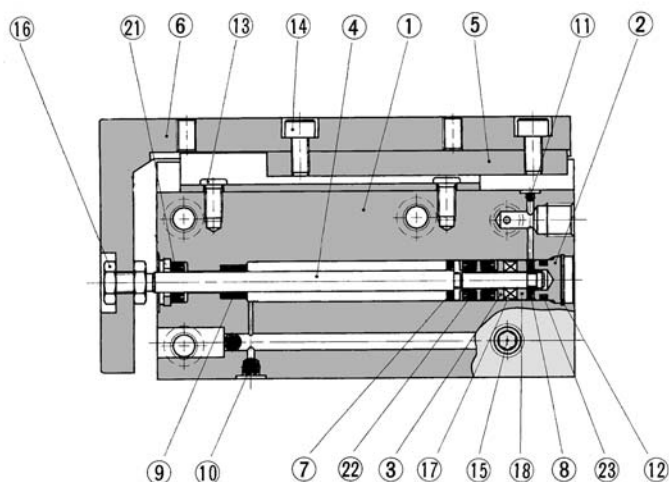

MXU10 (ø10)

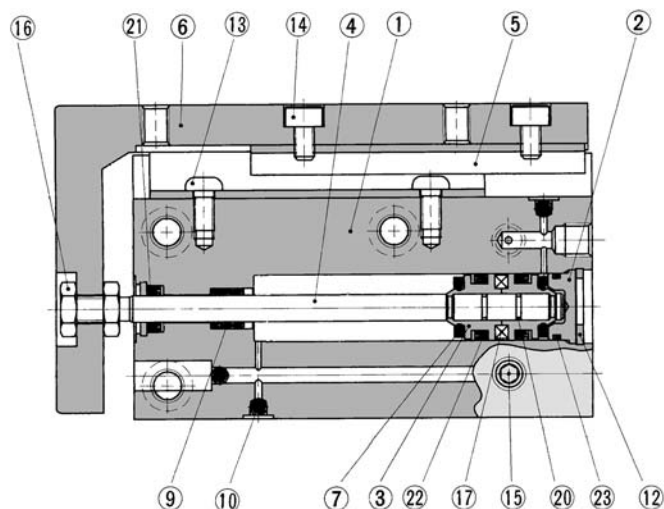

MXU16 (ø16)

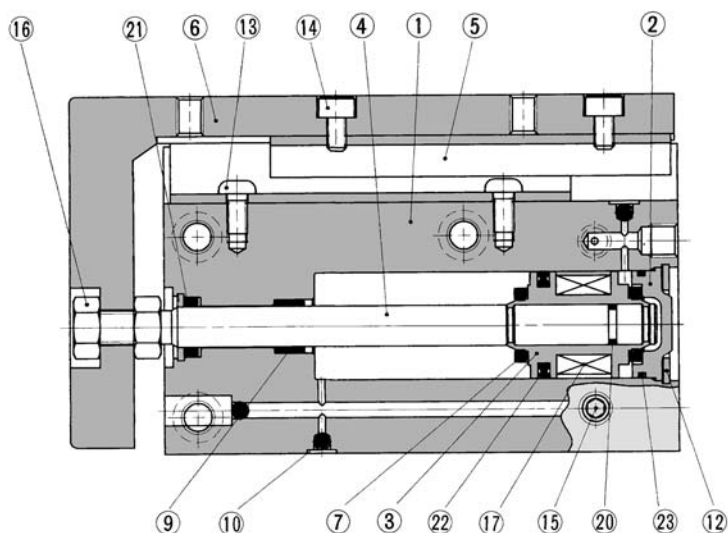

Con sensore

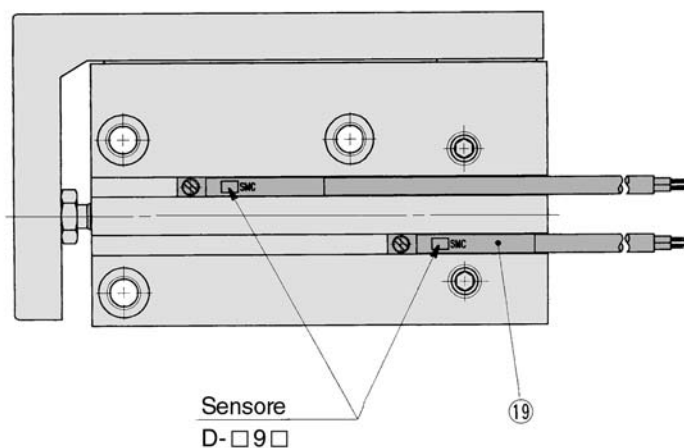

Componenti

N.	Descrizione	Materiale	Note
①	Tubo	Lega d'alluminio	Anodizzato duro
		Ottone	ø6, ø10 Nichelato per elettrolisi
②	Testata posteriore	Lega d'alluminio	ø16Cromato bianco
		Ottone	ø6, ø10
③	Pistone	Lega d'alluminio	ø16
④	Stelo	Acciaio inox	
⑤	Guida lineare miniaturizzata	—	
⑥	Tavola	Lega d'alluminio	Anodizzato duro
⑦	Ammortizzatore A	Uretano	
⑧	Ammortizzatore B	Uretano	
⑨	Bussola	Lega sinterizzata impregnata d'olio	Lega sinterizzata
⑩	Sfera d'acciaio A	Acciaio al cromo e carbonio	
⑪	Sfera d'acciaio B	Acciaio al cromo e carbonio	
⑫	Anello di ritegno C	Acciaio al carbonio per utensili	Rivestimento di fosfato
⑬	Vite con taglio a croce	Acciaio al carbonio	

Componenti

N.	Descrizione	Materiale	Note
⑭	Brugola	Acciaio al cromo molibdeno	Nichelato
⑮	Tappo con esagono incassato	Acciaio al cromo molibdeno	Nichelato
⑯	Dado estremità stelo	Acciaio al carbonio	Nichelato
		Anello magnetico	ø6, ø10 Nichelato
		Gomma sintetica	ø16
⑰	Anello magnetico	Gomma sintetica	ø16
⑱	Fermo magnete	Ottone	
⑲	Sensore	—	D- □ 9 □
⑳	Guarnizione pistone	NBR	
㉑	Guarnizione stelo	NBR	
㉒	Guarnizione pistone	NBR	
㉓	Guarnizione	NBR	



Sensori applicabili

Tipo di sensore	Modello	Connessione elettrica		Pag.
Sensori reed	D-A90	Grommet	Cavo assiale (In linea)	5.3-19
	D-A93			5.3-19
	D-A96			5.3-19
	D-A90V		Cavo assiale (Perpendicolare)	5.3-20
	D-A93V			5.3-20
	D-A96V			5.3-20
Sensori stato solido	D-M9N	Grommet	Cavo assiale (In linea)	5.3-39
	D-M9P			5.3-39
	D-M9B			5.3-39
	D-M9NV		Cavo assiale (Perpendicolare)	5.3-39
	D-M9PV			5.3-39
	D-M9BV			5.3-39
	D-M9NW		Cavo assiale (In linea)	5.3-66
	D-M9PW			5.3-66
	D-M9BW			5.3-66
	D-M9NWV		Cavo assiale (Perpendicolare)	5.3-66
	D-M9PWV			5.3-66
	D-M9BWV			5.3-66



Posizione montaggio sensori

D-A9□
D-M9□
D-M9□W

(): D-A93

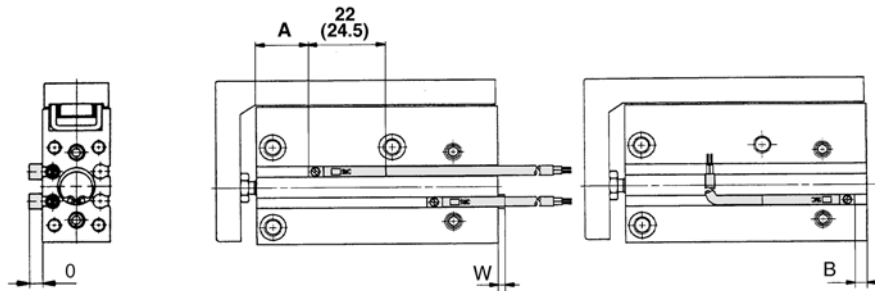

D-A9□V
D-M9□V
D-M9□WV

(): D-M9□V, D-M9□WV

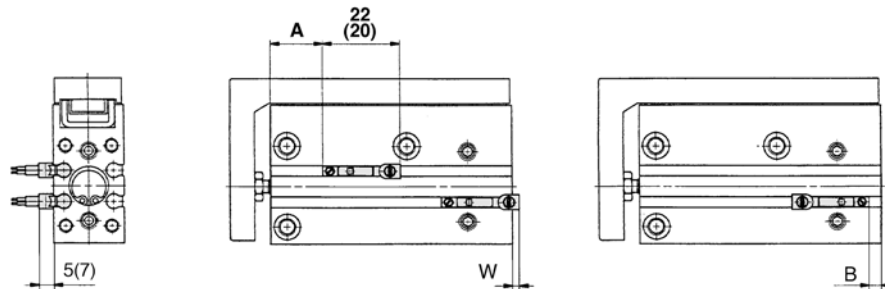

Esecuzione doppio effetto

(mm)

Diam.	Corsa	D-A9 □ /D-A9 □ V			D-M9B/D-M9P/D-M9N/D-M9□W			D-M9 □ V/D-M9 □ WV		
		A	B	W	A	B	W	A	B	W
6	5 30	13	0	2.5(5)	17	3.5	6.5	17	3.5	4.5
	5 20	13			17			17		
10	25 16	3.5	-1.5	(1)	20	7.5	2.5	20	7.5	0.5
	30 15				19			19		
16	5 23	4	-2	(0.5)	27	8	2	27	8	0
	10 18				22			22		
	15 23				27			27		
	20 18				22			22		
	25 23				27			27		
	30 23				27			27		

Nota 1) I modelli con "W" negativa vengono montati in modo tale da non sporgere dal cilindro.
 Nota 2) Su modelli con corsa 5 e 10, il sensore può non disattivarsi entro il campo operativo o due sensori potrebbero attivarsi contemporaneamente. Fissare i sensori da 1 a 4mm più esternamente dei valori in tabella.
 Nota 3) ():D-A93

Posizione scanalatura per sensore

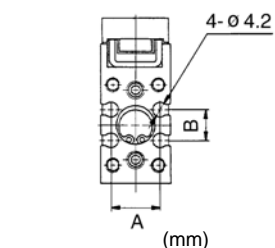

Diametro	A	B
6	10	6.9
10	14	8.8
16	19	13.9

Serie MXU

Corsa minima per montaggio sensori (mm)

Numero di sensori	Sensori applicabili		
	D-A9 □ D-A9 □ V	D-M9 □ D-M9 □ V	D-M9 □ W D-M9 □ WV
1 pz.	5	5	5
2 pz.	10	5	10

Montaggio sensori

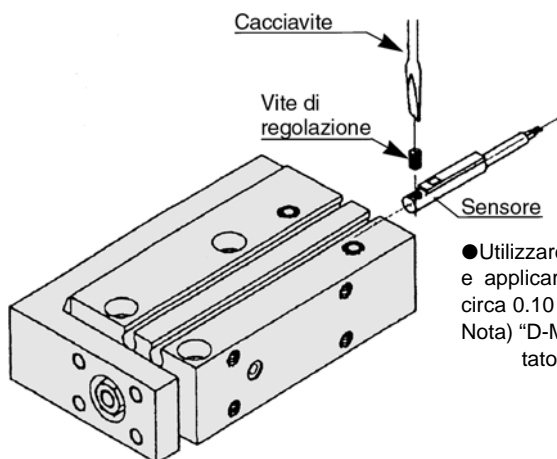

● Utilizzare un cacciavite di diam. 5÷6 mm e applicare una coppia di serraggio di circa 0.10 ÷ 0.20 Nm

Nota) "D-M9□V" non può essere montato con connessione laterale

Avvertenze per installazione ravvicinata

In caso di microslitta con sensori D-A9* o D-M9* rispettare la distanza minima mostrata in fig.[1] sennò i sensori possono attivarsi per errore. Se si dovessero installare con distanza minore, fornire i cilindri di una piastra d'acciaio o simili (MU-S025) da collocare sulla parte del cilindro che corrisponde ai sensori adiacenti. (Contattare SMC per ulteriori dettagli.)

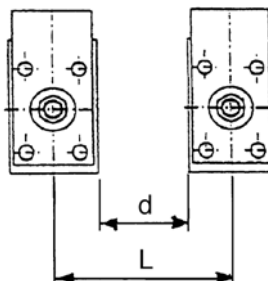

Tavola ① (mm)

Diametro (mm)	d	L
MXU6	5	21
MXU10	5	25
MXU16	10	35