

PULEGGE DENTATE POWERGRIP® PER CINGHIE POSITIVE

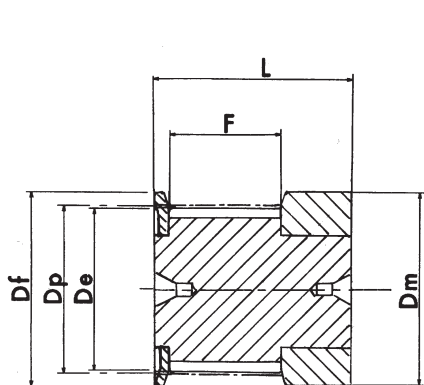

esecuzione 0F

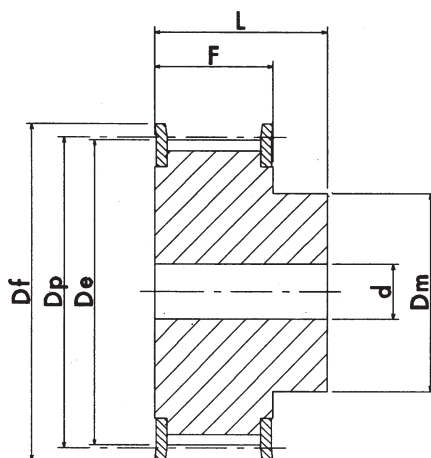

esecuzione 1F

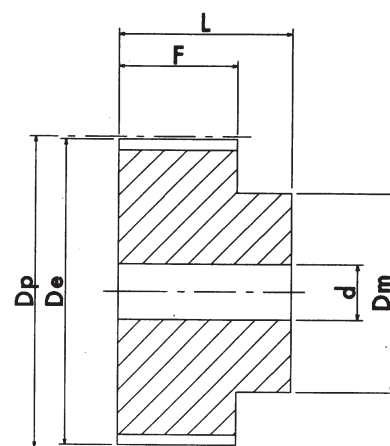

esecuzione 2

TIPO: MXL 025 PASSO 0.080" (2.032 mm.)

CARATTERISTICHE		Tipo	ESEC.	N. denti	Dp PRIMITIVO	De ESTERNO	Df FLANGIA	Dm MOZZO	F	L	d	FLANGIA N.	
ALLUMINIO	CON FLANGIA	16 MXL 025	0F	16	10.35	9.84	15	15	8.5	16	-	502	
		18 MXL 025	0F	18	11.64	11.12	16	16	8.5	16	-	503	
		20 MXL 025	0F	20	12.94	12.43	16	16	8.5	16	-	503	
		22 MXL 025	1F	22	14.23	13.72	17	10	11	16	3	504	
		24 MXL 025	1F	24	15.52	15.01	20	10	11	16	3	505	
		28 MXL 025	1F	28	18.11	17.60	25	11	11	16	3	506	
		30 MXL 025	1F	30	19.40	18.90	25	12	11	16	4	506	
		32 MXL 025	1F	32	20.70	20.19	26	14	11	16	4	507	
		36 MXL 025	1F	36	23.29	22.78	28	16	11	16	4	508	
		40 MXL 025	1F	40	25.87	25.37	32	18	11	16	4	509	
		42 MXL 025	1F	42	27.17	26.67	32	18	11	16	5	509	
		44 MXL 025	1F	44	28.46	27.95	36	18	11	16	5	510	
		SENZA FLANGIA	48 MXL 025	2	48	31.05	30.54	-	20	11	16	5	-
			60 MXL 025	2	60	38.81	38.30	-	24	11	16	5	-
72 MXL 025	2		72	46.57	46.06	-	25	11	16	6	-		

PULEGGE DENTATE POWERGRIP® PER CINGHIE POSITIVE

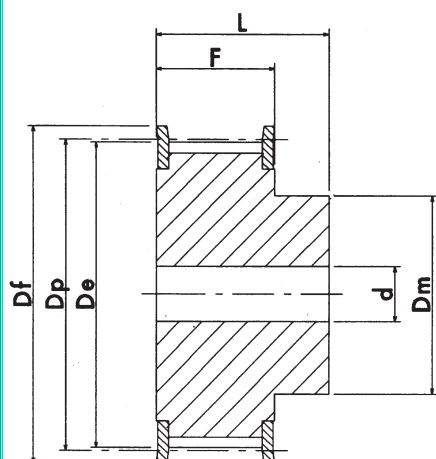

esecuzione 1F

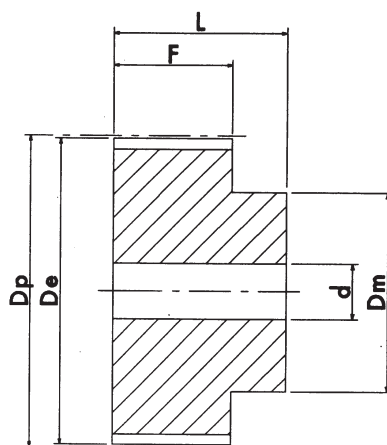

esecuzione 2

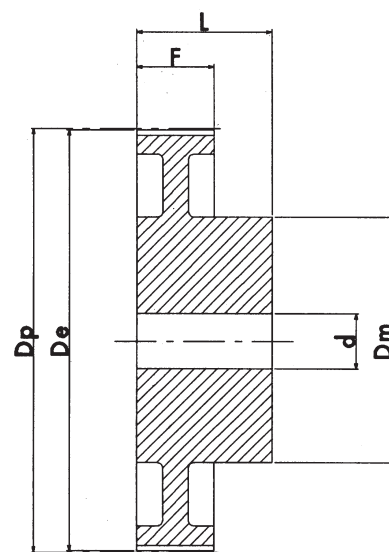

esecuzione 3

TIPO: XL 037 PASSO 1/5" (5.08 mm.)

CARATTERISTICHE		Typo	ESEC.	N. denti	Dp PRIMITIVO	De ESTERNO	Df FLANGIA	Dm MOZZO	F	L	d	FLANGIA N.
ACCIAIO/ALLUMINIO	CON FLANGIA	10 XL 037	1F	10	16.17	15.66	23.0	9.5	14.3	20	-	1
		11 XL 037	1F	11	17.79	17.28	23.0	9.5	14.3	20	-	1
		12 XL 037	1F	12	19.40	18.90	25.0	10	14.3	20	-	2
		13 XL 037	1F	13	21.02	20.51	25.0	10	14.3	20	-	2
		14 XL 037	1F	14	22.64	22.13	28.0	15	14.3	20	-	4
		15 XL 037	1F	15	24.26	23.75	28.0	15	14.3	20	-	4
		16 XL 037	1F	16	25.87	25.36	32.0	16	14.3	20	-	5
		17 XL 037	1F	17	27.49	26.98	32.0	20	14.3	20	-	6
		18 XL 037	1F	18	29.11	28.60	35.0	20	14.3	20	-	7
		19 XL 037	1F	19	30.72	30.22	35.0	20	14.3	22	-	7
		20 XL 037	1F	20	32.34	31.83	38.0	23.5	14.3	22	-	9
		21 XL 037	1F	21	33.96	33.45	38.0	23.5	14.3	22	-	9
		22 XL 037	1F	22	35.57	35.07	41.0	25	14.3	22	6	10
		24 XL 037	1F	24	38.81	38.30	44.0	30	14.3	22	6	12
		26 XL 037	1F	26	42.04	41.53	48.0	30	14.3	22	8	11
		27 XL 037	1F	27	43.66	43.15	48.0	30	14.3	22	8	11
		28 XL 037	1F	28	45.28	44.77	51.0	34	14.3	22	8	16
30 XL 037	1F	30	48.51	48.00	54.0	38	14.3	22	8	18		
32 XL 037	1F	32	51.74	51.24	57.0	38	14.3	25	8	20		
34 XL 037	1F	34	54.98	54.47	61.0	38	14.3	25	8	22		
35 XL 037	1F	35	56.60	56.09	61.0	38	14.3	25	8	22		
ALLUMINIO	SENZA FLANGIA	36 XL 037	2	36	58.21	57.70	-	45	14.3	25	8	-
		38 XL 037	2	38	61.45	60.94	-	45	14.3	25	8	-
		40 XL 037	2	40	64.68	64.17	-	45	14.3	25	8	-
		42 XL 037	2	42	67.91	67.41	-	45	14.3	25	8	-
		44 XL 037	2	44	71.15	70.64	-	45	14.3	25	8	-
		48 XL 037	3	48	77.62	77.11	-	45	14.3	25	10	-
		60 XL 037	3	60	97.02	96.51	-	45	14.3	25	10	-
72 XL 037	3	72	116.42	115.92	-	45	14.3	25	10	-		

PULEGGE DENTATE POWERGRIP® PER CINGHIE POSITIVE

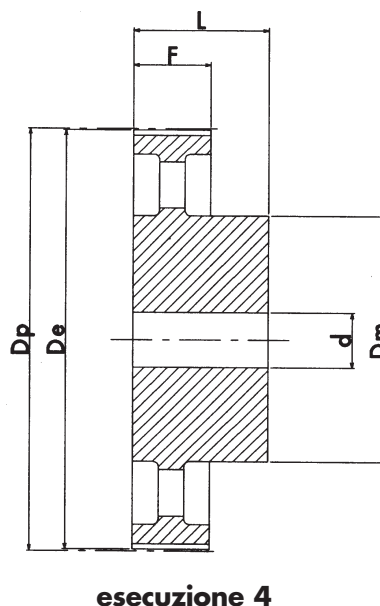
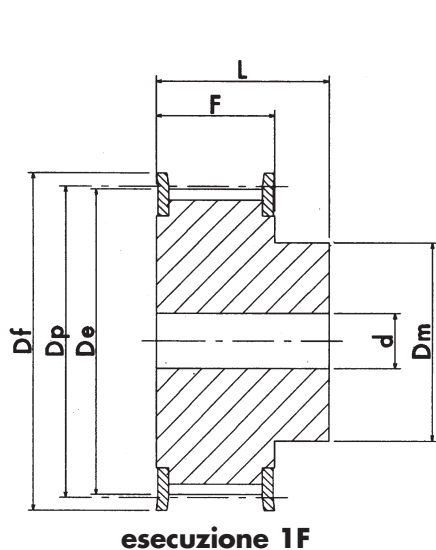

TIPO: L 050 PASSO 3/8" (9.52 mm.)

CARATTERISTICHE	Typo	ESEC.	N. denti	Dp PRIMITIVO	De ESTERNO	Df FLANGIA	Dm MOZZO	F	L	d	FLANGIA N.	
ACCIAIO	CON FLANGIA	10 L 050	1F	10	30.33	29.56	37.00	20	19.0	28	8	50
		11 L 050	1F	11	33.35	32.59	37.00	22	19.0	30	8	50
		12 L 050	1F	12	36.37	35.62	43.00	24	19.0	30	8	52
		13 L 050	1F	13	39.41	38.65	44.00	28	19.0	30	8	83
		14 L 050	1F	14	42.44	41.68	48.00	28	19.0	30	8	54
		15 L 050	1F	15	45.48	44.72	51.00	34	19.0	30	8	55
		16 L 050	1F	16	48.51	47.75	54.00	36	19.0	32	8	56
		17 L 050	1F	17	51.54	50.78	57.00	36	19.0	32	10	57
		18 L 050	1F	18	54.59	53.81	60.00	40	19.0	32	10	58
		19 L 050	1F	19	57.61	56.84	64.00	40	19.0	32	10	59
		20 L 050	1F	20	60.63	59.88	66.50	40	19.0	32	10	60
		21 L 050	1F	21	63.68	62.91	70.00	45	19.0	32	10	61
		22 L 050	1F	22	66.70	65.94	75.00	45	19.0	32	10	62
		23 L 050	1F	23	69.73	68.97	79.00	55	19.0	32	10	63
		24 L 050	1F	24	72.77	72.00	79.00	55	19.0	32	10	63
		25 L 050	1F	25	75.80	75.04	82.50	58	19.0	32	10	64
		26 L 050	1F	26	78.84	78.07	86.00	58	19.0	32	11	65
		27 L 050	1F	27	81.86	81.10	86.00	58	19.0	32	11	65
		28 L 050	1F	28	84.89	84.13	91.00	58	19.0	32	11	66
		30 L 050	1F	30	90.96	90.20	97.00	70	19.0	32	11	68
		32 L 050	1F	32	97.03	96.26	102.00	70	19.0	32	11	70
		33 L 050	1F	33	100.05	99.29	106.00	70	19.0	32	11	71
		34 L 050	1F	34	103.08	102.32	112.00	70	19.0	32	11	72
		35 L 050	1F	35	106.12	105.35	112.00	70	19.0	32	11	72
		36 L 050	1F	36	109.14	108.39	115.00	70	19.0	32	11	74
		40 L 050	1F	40	121.29	120.51	128.00	70	19.0	32	11	78
		42 L 050	1F	42	127.34	126.57	135.00	70	19.0	32	11	80
		44 L 050	1F	44	133.40	132.64	142.00	70	19.0	32	11	81
45 L 050	1F	45	136.44	135.67	142.00	70	19.0	32	11	81		
48 L 050	1F	48	145.54	144.77	150.00	70	19.0	32	11	85		
GHISA	SENZA FLANGIA	50 L 050	4	50	151.60	150.83	-	70	19.0	32	14	-
		52 L 050	4	52	157.66	156.90	-	70	19.0	32	14	-
		56 L 050	4	56	169.79	169.02	-	70	19.0	32	14	-
		57 L 050	4	57	172.82	172.06	-	70	19.0	32	14	-
		60 L 050	4	60	181.92	181.15	-	75	19.0	42	14	-
		72 L 050	4	72	218.29	217.53	-	75	19.0	42	14	-
		84 L 050	4	84	254.69	253.92	-	75	19.0	42	14	-
		96 L 050	4	96	291.06	290.30	-	75	19.0	42	14	-

PULEGGE DENTATE POWERGRIP® PER CINGHIE POSITIVE

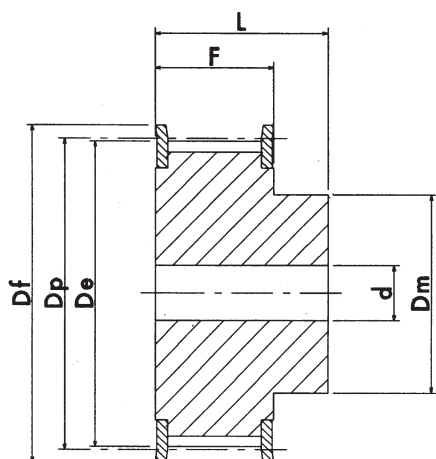

esecuzione 1F

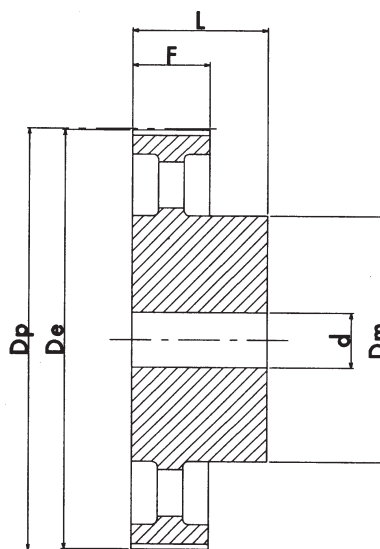

esecuzione 4

TIPO: L 075 PASSO 3/8" (9.52 mm.)

CARATTERISTICHE	Tipo	ESEC.	N. denti	Dp PRIMITIVO	De ESTERNO	Df FLANGIA	Dm MOZZO	F	L	d	FLANGIA N.
ACCIAIO	10 L 075	1F	10	30.33	29.56	37.0	20	25.4	38	8	50
	11 L 075	1F	11	33.35	32.59	37.0	22	25.4	38	8	50
	12 L 075	1F	12	36.37	35.62	43.0	24	25.4	38	8	52
	13 L 075	1F	13	39.41	38.65	44.0	28	25.4	38	8	83
	14 L 075	1F	14	42.44	41.68	48.0	28	25.4	38	11	54
	15 L 075	1F	15	45.48	44.72	51.0	34	25.4	38	11	55
	16 L 075	1F	16	48.51	47.75	54.0	36	25.4	38	11	56
	17 L 075	1F	17	51.54	50.78	57.0	36	25.4	38	11	57
	18 L 075	1F	18	54.59	53.81	60.0	40	25.4	38	11	58
	19 L 075	1F	19	57.61	56.84	64.0	40	25.4	38	11	59
	20 L 075	1F	20	60.63	59.88	66.5	40	25.4	38	11	60
	21 L 075	1F	21	63.68	62.91	70.0	45	25.4	38	11	61
	22 L 075	1F	22	66.70	65.94	75.0	45	25.4	38	11	62
	23 L 075	1F	23	69.73	68.97	79.0	55	25.4	38	11	63
	24 L 075	1F	24	72.77	72.00	79.0	55	25.4	38	11	63
	25 L 075	1F	25	75.80	75.04	82.5	58	25.4	38	11	64
	26 L 075	1F	26	78.84	78.07	86.0	58	25.4	38	11	65
	27 L 075	1F	27	81.86	81.10	86.0	58	25.4	38	11	65
	28 L 075	1F	28	84.89	84.13	91.0	58	25.4	38	11	66
	30 L 075	1F	30	90.96	90.20	97.0	70	25.4	38	11	68
	32 L 075	1F	32	97.03	96.26	102.0	70	25.4	38	11	70
	33 L 075	1F	33	100.05	99.29	106.0	70	25.4	38	11	71
	34 L 075	1F	34	103.08	102.32	112.0	70	25.4	38	11	72
	35 L 075	1F	35	106.12	105.35	112.0	70	25.4	38	11	72
36 L 075	1F	36	109.14	108.39	115.0	70	25.4	38	11	74	
40 L 075	1F	40	121.29	120.51	128.0	70	25.4	38	11	78	
42 L 075	1F	42	127.34	126.57	135.0	70	25.4	38	11	80	
44 L 075	1F	44	133.40	132.64	142.0	70	25.4	38	11	81	
45 L 075	1F	45	136.44	135.67	142.0	70	25.4	38	11	81	
48 L 075	1F	48	145.54	144.77	150.0	70	25.4	38	11	85	
GHISA	50 L 075	4	50	151.60	150.83	-	70	25.4	38	14	-
	52 L 075	4	52	157.66	156.90	-	70	25.4	38	14	-
	56 L 075	4	56	169.79	169.02	-	70	25.4	38	14	-
	57 L 075	4	57	172.82	172.06	-	70	25.4	38	14	-
	60 L 075	4	60	181.92	181.15	-	75	25.4	45	14	-
	72 L 075	4	72	218.29	217.53	-	75	25.4	45	14	-
	84 L 075	4	84	254.69	253.92	-	75	25.4	45	14	-
	96 L 075	4	96	291.06	290.30	-	75	25.4	45	14	-

PULEGGE DENTATE POWERGRIP® PER CINGHIE POSITIVE

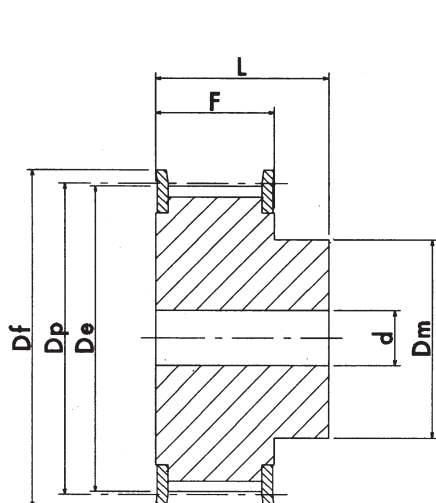

esecuzione 1F

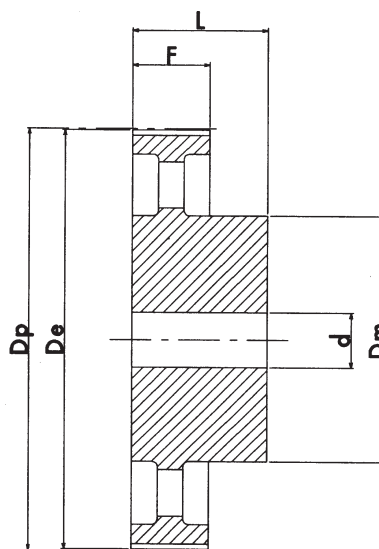

esecuzione 4

TIPO: L 100 PASSO 3/8" (9.52 mm.)

CARATTERISTICHE	Typo	ESEC.	N. denti	Dp PRIMITIVO	De ESTERNO	Df FLANGIA	Dm MOZZO	F	L	d	FLANGIA N.	
ACCIAIO	CON FLANGIA	10 L 100	1F	10	30.33	29.56	37.0	20	31.8	45	8	50
		11 L 100	1F	11	33.35	32.59	37.0	22	31.8	45	8	50
		12 L 100	1F	12	36.37	35.62	43.0	24	31.8	45	8	52
		13 L 100	1F	13	39.41	38.65	44.0	28	31.8	45	8	83
		14 L 100	1F	14	42.44	41.68	48.0	28	31.8	45	11	54
		15 L 100	1F	15	45.48	44.72	51.0	34	31.8	45	11	55
		16 L 100	1F	16	48.51	47.75	54.0	36	31.8	45	11	56
		17 L 100	1F	17	51.54	50.78	57.0	36	31.8	45	11	57
		18 L 100	1F	18	54.59	53.81	60.0	40	31.8	45	11	58
		19 L 100	1F	19	57.61	56.84	64.0	40	31.8	45	11	59
		20 L 100	1F	20	60.63	59.88	66.5	40	31.8	45	11	60
		21 L 100	1F	21	63.68	62.91	70.0	45	31.8	45	11	61
		22 L 100	1F	22	66.70	65.94	75.0	45	31.8	45	11	62
		23 L 100	1F	23	69.73	68.97	79.0	55	31.8	45	11	63
		24 L 100	1F	24	72.77	72.00	79.0	55	31.8	45	11	63
		25 L 100	1F	25	75.80	75.04	82.5	58	31.8	45	11	64
		26 L 100	1F	26	78.84	78.07	86.0	58	31.8	45	11	65
		27 L 100	1F	27	81.86	81.10	86.0	58	31.8	45	11	65
		28 L 100	1F	28	84.89	84.13	91.0	58	31.8	45	11	66
		30 L 100	1F	30	90.96	90.20	97.0	70	31.8	45	11	68
		32 L 100	1F	32	97.03	96.26	102.0	70	31.8	45	11	70
		33 L 100	1F	33	100.05	99.29	106.0	70	31.8	45	11	71
		34 L 100	1F	34	103.08	102.32	112.0	70	31.8	45	11	72
		35 L 100	1F	35	106.12	105.35	112.0	70	31.8	45	11	72
		36 L 100	1F	36	109.14	108.39	115.0	70	31.8	45	11	74
		40 L 100	1F	40	121.29	120.51	128.0	70	31.8	45	11	78
		42 L 100	1F	42	127.34	126.57	135.0	70	31.8	45	11	80
		44 L 100	1F	44	133.40	132.64	142.0	70	31.8	45	11	81
45 L 100	1F	45	136.44	135.67	142.0	70	31.8	45	11	81		
48 L 100	1F	48	145.54	144.77	150.0	70	31.8	45	11	85		
GHISA	SENZA FLANGIA	50 L 100	4	50	151.60	150.83	-	70	31.8	45	14	-
		52 L 100	4	52	157.66	156.90	-	70	31.8	45	14	-
		56 L 100	4	56	169.79	169.02	-	70	31.8	45	14	-
		57 L 100	4	57	172.82	172.06	-	70	31.8	45	14	-
		60 L 100	4	60	181.92	181.15	-	75	31.8	45	14	-
		72 L 100	4	72	218.29	217.53	-	75	31.8	45	14	-
		84 L 100	4	84	254.69	253.92	-	75	31.8	45	14	-
		96 L 100	4	96	291.06	290.30	-	75	31.8	45	14	-

PULEGGE DENTATE POWERGRIP® PER CINGHIE POSITIVE

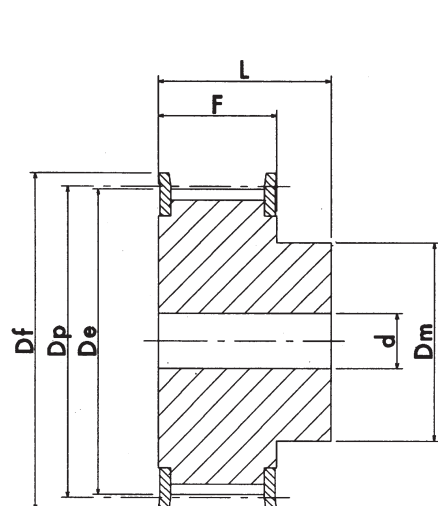

esecuzione 1F

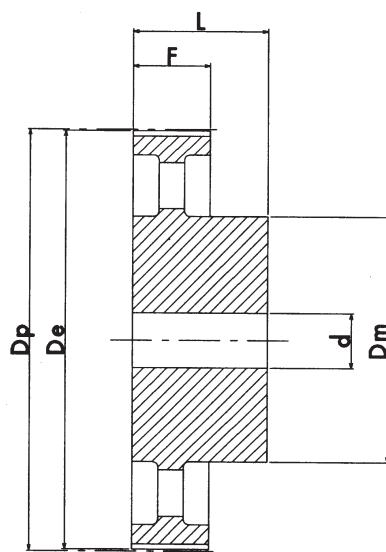

esecuzione 4

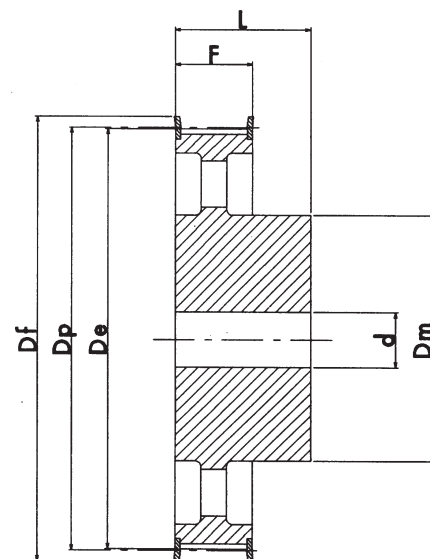

esecuzione 5F

TIPO: H 075 PASSO 1/2" (12.7 mm.)

CARATTERISTICHE	Typo	ESEC.	N. denti	Dp PRIMITIVO	De ESTERNO	Df FLANGIA	Dm MOZZO	F	L	d	FLANGIA N.	
ACCIAIO	CON FLANGIA	14 H 075	1F	14	56.59	55.22	64.0	40	26.4	40	-	59
		15 H 075	1F	15	60.64	59.27	66.5	45	26.4	40	-	60
		16 H 075	1F	16	64.67	63.31	70.0	45	26.4	40	-	61
		17 H 075	1F	17	68.72	67.35	75.0	45	26.4	40	-	62
		18 H 075	1F	18	72.77	71.39	79.0	55	26.4	40	-	63
		19 H 075	1F	19	76.81	75.44	82.5	60	26.4	40	11	64
		20 H 075	1F	20	80.85	79.48	87.0	62	26.4	40	11	76
		21 H 075	1F	21	84.89	83.52	91.0	65	26.4	40	11	66
		22 H 075	1F	22	88.93	87.56	94.0	68	26.4	40	11	67
		23 H 075	1F	23	92.98	91.61	97.0	72	26.4	40	11	68
		24 H 075	1F	24	97.03	95.65	102.0	72	26.4	40	11	70
		25 H 075	1F	25	101.06	99.69	106.0	72	26.4	40	11	71
		26 H 075	1F	26	105.11	103.73	112.0	80	26.4	40	11	72
		27 H 075	1F	27	109.15	107.78	115.0	80	26.4	40	11	74
		28 H 075	1F	28	113.18	111.82	120.0	80	26.4	40	11	75
		30 H 075	1F	30	121.29	119.90	128.0	80	26.4	40	11	78
		32 H 075	1F	32	129.30	127.99	135.0	80	26.4	40	11	80
		33 H 075	1F	33	133.40	132.03	142.0	80	26.4	40	11	81
		34 H 075	1F	34	137.45	136.07	142.0	80	26.4	40	11	81
		35 H 075	1F	35	141.49	140.12	150.0	80	26.4	40	11	85
36 H 075	1F	36	145.54	144.16	150.0	80	26.4	40	11	85		
38 H 075	1F	38	153.62	152.24	158.0	80	26.4	40	11	86		
40 H 075	1F	40	161.70	160.33	168.0	80	26.4	40	11	90		
42 H 075	1F	42	169.79	168.41	184.0	80	26.4	40	11	94		
GHISA	SENZA FLANGIA	44 H 075	5F	44	177.80	176.50	184.0	80	26.4	40	14	95
		48 H 075	5F	48	194.03	192.67	200.0	90	26.4	45	14	100
		50 H 075	4	50	202.13	200.75	-	90	26.4	45	14	-

PULEGGE DENTATE POWERGRIP® PER CINGHIE POSITIVE

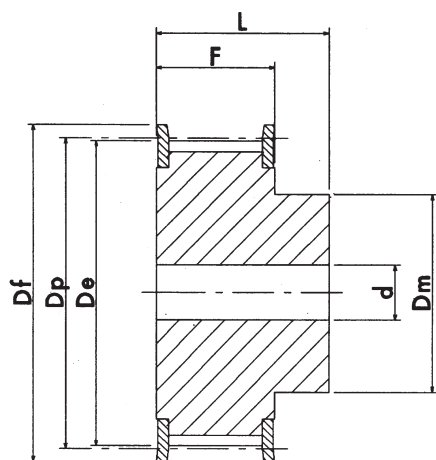

esecuzione 1F

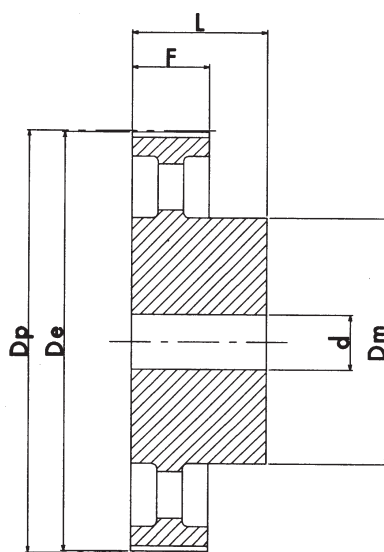

esecuzione 4

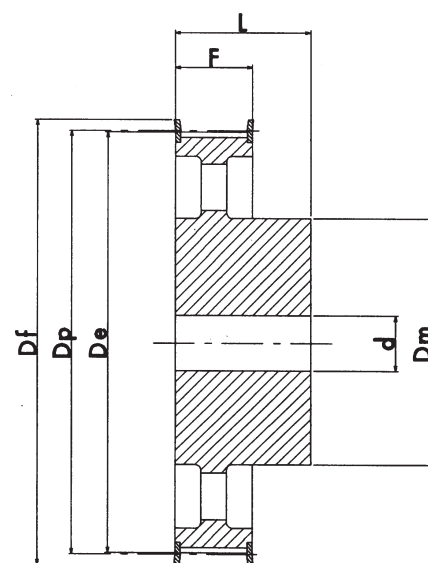

esecuzione 5F

TIPO: H 100 PASSO 1/2" (12.7 mm.)

CARATTERISTICHE	Typo	ESEC.	N. denti	Dp PRIMITIVO	De ESTERNO	Df FLANGIA	Dm MOZZO	F	L	d	FLANGIA N.	
ACCIAIO	CON FLANGIA	14 H 100	1F	14	56.59	55.22	64.0	40	31.8	45	-	59
		15 H 100	1F	15	60.64	59.27	66.5	45	31.8	45	-	60
		16 H 100	1F	16	64.67	63.31	70.0	45	31.8	45	-	61
		17 H 100	1F	17	68.72	67.35	75.0	45	31.8	45	-	62
		18 H 100	1F	18	72.77	71.39	79.0	55	31.8	45	-	63
		19 H 100	1F	19	76.81	75.44	82.5	60	31.8	45	14	64
		20 H 100	1F	20	80.85	79.48	87.0	62	31.8	45	14	76
		21 H 100	1F	21	84.89	83.52	91.0	65	31.8	45	14	66
		22 H 100	1F	22	88.93	87.56	94.0	68	31.8	45	14	67
		23 H 100	1F	23	92.98	91.61	97.0	72	31.8	45	14	68
		24 H 100	1F	24	97.03	95.65	102.0	72	31.8	45	14	70
		25 H 100	1F	25	101.06	99.69	106.0	72	31.8	45	14	71
		26 H 100	1F	26	105.11	103.73	112.0	80	31.8	45	14	72
		27 H 100	1F	27	109.15	107.78	115.0	80	31.8	45	14	74
		28 H 100	1F	28	113.18	111.82	120.0	80	31.8	45	14	75
		29 H 100	1F	29	117.23	115.86	120.0	80	31.8	45	14	75
		30 H 100	1F	30	121.29	119.90	128.0	80	31.8	45	14	78
		32 H 100	1F	32	129.30	127.99	135.0	80	31.8	45	14	80
		33 H 100	1F	33	133.40	132.03	142.0	80	31.8	45	14	81
		34 H 100	1F	34	137.45	136.07	142.0	80	31.8	45	14	81
35 H 100	1F	35	141.49	140.12	150.0	80	31.8	45	14	85		
36 H 100	1F	36	145.54	144.16	150.0	80	31.8	45	14	85		
38 H 100	1F	38	153.62	152.24	158.0	80	31.8	45	14	86		
40 H 100	1F	40	161.70	160.33	168.0	80	31.8	45	14	90		
42 H 100	1F	42	169.79	168.41	180.0	80	31.8	45	14	94		
GHISA	SENZA FLANGIA	44 H 100	5F	44	177.88	176.50	184.0	80	31.8	50	14	95
		45 H 100	5F	45	181.91	180.54	192.0	80	31.8	50	14	96
		48 H 100	5F	48	194.03	192.67	200.0	90	31.8	50	14	100
	CON FLANGIA	50 H 100	4	50	202.13	200.75	-	90	31.8	50	19	-
		52 H 100	4	52	210.21	208.84	-	90	31.8	50	19	-
		58 H 100	4	58	234.47	233.09	-	90	31.8	50	19	-
		60 H 100	4	60	242.55	241.18	-	120	31.8	50	19	-
		70 H 100	4	70	282.98	281.61	-	120	31.8	55	19	-
		72 H 100	4	72	291.06	289.69	-	120	31.8	55	19	-
		84 H 100	4	84	339.57	338.20	-	120	31.8	55	19	-
		96 H 100	4	96	388.09	386.71	-	120	31.8	60	19	-
		120 H 100	4	120	485.12	483.73	-	120	31.8	60	19	-

PULEGGE DENTATE POWERGRIP® PER CINGHIE POSITIVE

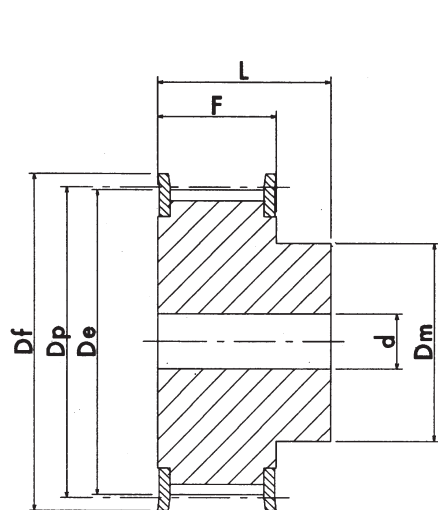

esecuzione 1F

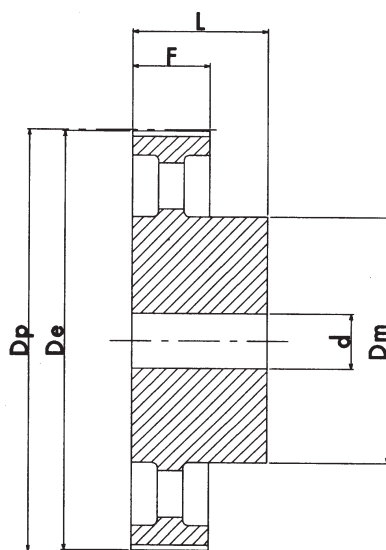

esecuzione 4

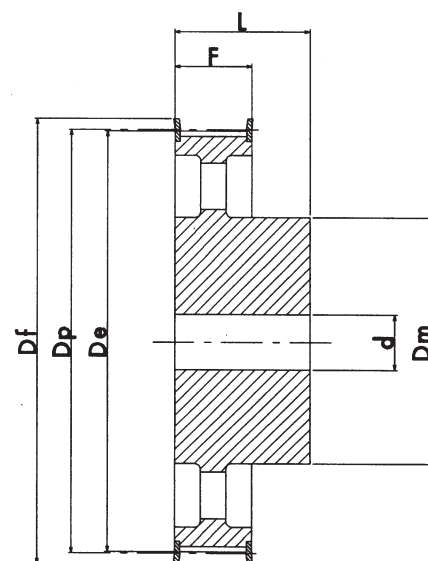

esecuzione 5F

TIPO: H 150 PASSO 1/2" (12.7 mm.)

CARATTERISTICHE	Typo	ESEC.	N. denti	Dp PRIMITIVO	De ESTERNO	Df FLANGIA	Dm MOZZO	F	L	d	FLANGIA N.	
ACCIAIO	CON FLANGIA	14 H 150	1F	14	56.59	55.22	64.0	42	46.0	58	-	59
		15 H 150	1F	15	60.64	59.27	66.5	45	46.0	58	-	60
		16 H 150	1F	16	64.67	63.31	70.0	45	46.0	58	-	61
		17 H 150	1F	17	68.72	67.35	75.0	45	46.0	58	-	62
		18 H 150	1F	18	72.77	71.39	79.0	55	46.0	58	-	63
		19 H 150	1F	19	76.81	75.44	82.5	60	46.0	58	-	64
		20 H 150	1F	20	80.85	79.48	87.0	62	46.0	58	-	76
		21 H 150	1F	21	84.89	83.52	91.0	65	46.0	58	-	66
		22 H 150	1F	22	88.93	87.56	94.0	68	46.0	58	-	67
		23 H 150	1F	23	92.98	91.61	97.0	72	46.0	58	-	68
		24 H 150	1F	24	97.03	95.65	102.0	72	46.0	58	-	70
		25 H 150	1F	25	101.06	99.69	106.0	72	46.0	58	-	71
		26 H 150	1F	26	105.11	103.73	112.0	80	46.0	58	-	72
		27 H 150	1F	27	109.15	107.78	115.0	80	46.0	58	-	74
		28 H 150	1F	28	113.18	111.82	120.0	80	46.0	58	-	75
		29 H 150	1F	29	117.23	115.86	120.0	80	46.0	58	-	75
		30 H 150	1F	30	121.29	119.90	128.0	80	46.0	58	-	78
		32 H 150	1F	32	129.30	127.99	135.0	80	46.0	58	-	80
		33 H 150	1F	33	133.40	132.03	142.0	80	46.0	58	-	81
		34 H 150	1F	34	137.45	136.07	142.0	80	46.0	58	-	81
		35 H 150	1F	35	141.49	140.12	150.0	80	46.0	58	-	85
		36 H 150	1F	36	145.54	144.16	150.0	80	46.0	58	-	85
		38 H 150	1F	38	153.62	152.24	158.0	80	46.0	58	-	86
		40 H 150	1F	40	161.70	160.33	168.0	80	46.0	58	-	90
42 H 150	1F	42	169.79	168.41	180.0	80	46.0	58	-	94		
GHISA	SENZA FLANGIA	44 H 150	5F	44	177.88	176.50	184.00	80	46.0	58	19	95
		45 H 150	5F	45	181.91	180.54	192.00	80	46.0	58	19	96
		48 H 150	5F	48	194.03	192.67	200.00	90	46.0	65	19	100
		50 H 150	4	50	202.13	200.75	-	90	46.0	65	19	-
		52 H 150	4	52	210.21	208.84	-	90	46.0	65	19	-
		58 H 150	4	58	234.47	233.09	-	90	46.0	65	19	-
		60 H 150	4	60	242.55	241.18	-	120	46.0	65	19	-
		70 H 150	4	70	282.98	281.61	-	120	46.0	65	24	-
		72 H 150	4	72	291.06	289.69	-	120	46.0	65	24	-
		84 H 150	4	84	339.57	338.20	-	120	46.0	65	24	-
		96 H 150	4	96	388.09	386.71	-	120	46.0	65	24	-
		120 H 150	4	120	485.12	483.73	-	120	46.0	65	24	-

PULEGGE DENTATE POWERGRIP® PER CINGHIE POSITIVE

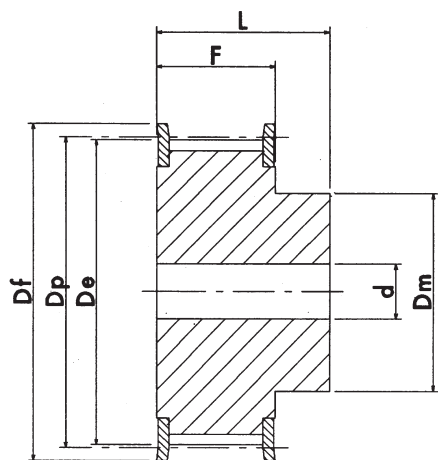

esecuzione 1F

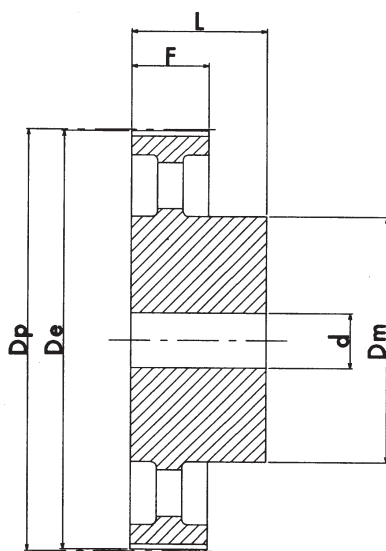

esecuzione 4

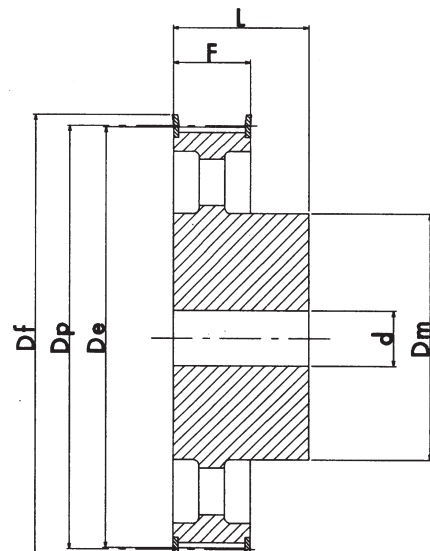

esecuzione 5F

TIPO: H 200 PASSO 1/2" (12.7 mm.)

CARATTERISTICHE	Typo	ESEC.	N. denti	Dp PRIMITIVO	De ESTERNO	Df FLANGIA	Dm MOZZO	F	L	d	FLANGIA N.	
ACCIAIO	CON FLANGIA	14 H 200	1F	14	56.59	55.22	64.0	42	58.7	70	-	59
		15 H 200	1F	15	60.64	59.27	66.5	45	58.7	70	-	60
		16 H 200	1F	16	64.67	63.31	70.0	45	58.7	70	-	61
		17 H 200	1F	17	68.72	67.35	75.0	45	58.7	70	-	62
		18 H 200	1F	18	72.77	71.39	79.0	55	58.7	70	-	63
		19 H 200	1F	19	76.81	75.44	82.5	60	58.7	70	-	64
		20 H 200	1F	20	80.85	79.48	87.0	62	58.7	70	-	76
		21 H 200	1F	21	84.89	83.52	91.0	65	58.7	70	-	66
		22 H 200	1F	22	88.93	87.56	94.0	68	58.7	70	-	67
		23 H 200	1F	23	92.98	91.61	97.0	72	58.7	70	-	68
		24 H 200	1F	24	97.03	95.65	102.0	72	58.7	70	-	70
		25 H 200	1F	25	101.06	99.69	106.0	72	58.7	70	-	71
		26 H 200	1F	26	105.11	103.73	112.0	80	58.7	70	-	72
		27 H 200	1F	27	109.15	107.78	115.0	80	58.7	70	-	74
		28 H 200	1F	28	113.18	111.82	120.0	80	58.7	70	-	75
		29 H 200	1F	29	117.23	115.86	120.0	80	58.7	70	-	75
		30 H 200	1F	30	121.29	119.90	128.0	80	58.7	70	-	78
		32 H 200	1F	32	129.30	127.99	135.0	80	58.7	70	-	80
		33 H 200	1F	33	133.40	132.03	142.0	80	58.7	70	-	81
		34 H 200	1F	34	137.45	136.07	142.0	80	58.7	70	-	81
		35 H 200	1F	35	141.49	140.12	150.0	80	58.7	70	-	85
36 H 200	1F	36	145.54	144.16	150.0	80	58.7	70	-	85		
38 H 200	1F	38	153.62	152.24	158.0	80	58.7	70	-	86		
40 H 200	1F	40	161.70	160.33	168.0	80	58.7	70	-	90		
42 H 200	1F	42	169.79	168.41	180.0	80	58.7	70	-	94		
GHISA	SENZA FLANGIA	44 H 200	5F	44	177.88	176.50	184.0	80	58.7	70	19	95
		45 H 200	5F	45	181.91	180.54	192.0	80	58.7	70	19	96
		48 H 200	5F	48	194.03	192.67	200.0	90	58.7	75	24	100
	SENZA FLANGIA	50 H 200	4	50	202.13	200.75	-	90	58.7	75	24	-
		52 H 200	4	52	210.21	208.84	-	90	58.7	75	24	-
		58 H 200	4	58	234.47	233.09	-	90	58.7	75	24	-
		60 H 200	4	60	242.55	241.18	-	120	58.7	75	24	-
		70 H 200	4	70	282.98	281.61	-	120	58.7	75	28	-
		72 H 200	4	72	291.06	289.69	-	120	58.7	75	28	-
		84 H 200	4	84	339.57	338.20	-	120	58.7	75	28	-
		96 H 200	4	96	388.09	386.71	-	120	58.7	75	28	-
		120 H 200	4	120	485.12	483.73	-	120	58.7	75	28	-

PULEGGE DENTATE POWERGRIP® PER CINGHIE POSITIVE

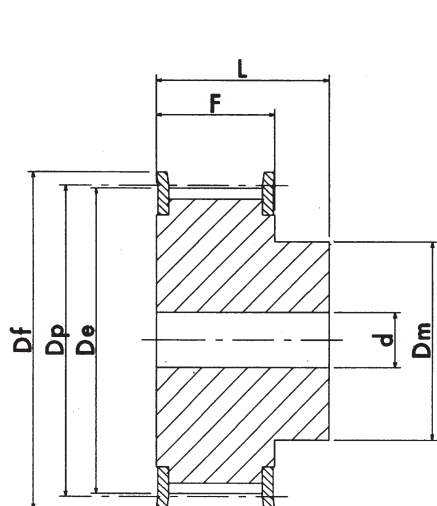

esecuzione 1F

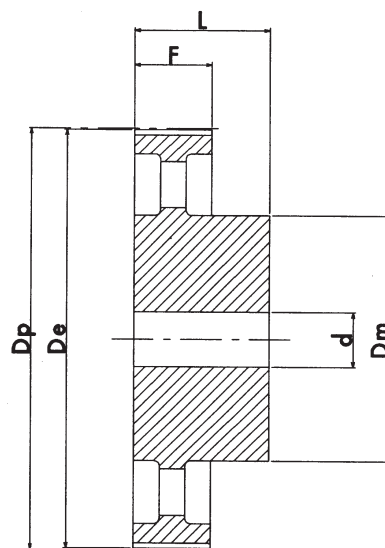

esecuzione 4

TIPO: H 300 PASSO 1/2" (12.7 mm.)

CARATTERISTICHE		Typo	ESEC.	N. denti	Dp PRIMITIVO	De ESTERNO	Df FLANGIA	Dm MOZZO	F	L	d	FLANGIA N.
ACCIAIO	CON FLANGIA	14 H 300	1F	14	56.59	55.22	64.0	42	85.7	100	-	59
		15 H 300	1F	15	60.64	59.27	66.5	45	85.7	100	-	60
		16 H 300	1F	16	64.67	63.31	70.0	45	85.7	100	-	61
		17 H 300	1F	17	68.72	67.35	75.0	45	85.7	100	-	62
		18 H 300	1F	18	72.77	71.39	79.0	55	85.7	100	-	63
		19 H 300	1F	19	76.81	75.44	82.5	60	85.7	100	-	64
		20 H 300	1F	20	80.85	79.48	87.0	62	85.7	100	-	76
		21 H 300	1F	21	84.89	83.52	91.0	65	85.7	100	-	66
		22 H 300	1F	22	88.93	87.56	94.0	68	85.7	100	-	67
		23 H 300	1F	23	92.98	91.61	97.0	72	85.7	100	-	68
		24 H 300	1F	24	97.03	95.65	102.0	72	85.7	100	-	70
		25 H 300	1F	25	101.06	99.69	106.0	72	85.7	100	-	71
		26 H 300	1F	26	105.11	103.73	112.0	80	85.7	100	-	72
		27 H 300	1F	27	109.15	107.78	115.0	80	85.7	100	-	74
		28 H 300	1F	28	113.18	111.82	120.0	80	85.7	100	-	75
		30 H 300	1F	30	121.29	119.90	128.0	80	85.7	100	-	78
		32 H 300	1F	32	129.30	127.99	135.0	80	85.7	100	-	80
		33 H 300	1F	33	133.40	132.03	142.0	80	85.7	100	-	81
		34 H 300	1F	34	137.45	136.07	142.0	80	85.7	100	-	81
		35 H 300	1F	35	141.49	140.12	150.0	80	85.7	100	-	85
36 H 300	1F	36	145.54	144.16	150.0	80	85.7	100	-	85		
38 H 300	1F	38	153.62	152.24	158.0	80	85.7	100	-	86		
40 H 300	1F	40	161.70	160.33	168.0	80	85.7	100	-	90		
42 H 300	1F	42	169.79	168.41	180.0	80	85.7	100	-	94		
GHISA	SENZA FLANGIA	44 H 300	4	44	177.88	176.50	-	80	85.7	100	24	-
		48 H 300	4	48	194.03	192.67	-	90	85.7	100	24	-
		50 H 300	4	50	202.13	200.75	-	90	85.7	100	24	-
		58 H 300	4	58	234.47	233.09	-	90	85.7	100	24	-
		60 H 300	4	60	242.55	241.18	-	120	85.7	100	24	-
		72 H 300	4	72	291.06	289.69	-	120	85.7	100	28	-
		84 H 300	4	84	339.57	338.20	-	120	85.7	100	28	-
		96 H 300	4	96	388.09	386.71	-	120	85.7	100	28	-
120 H 300	4	120	485.12	483.73	-	120	85.7	100	28	-		

PULEGGE DENTATE POWERGRIP® PER CINGHIE POSITIVE

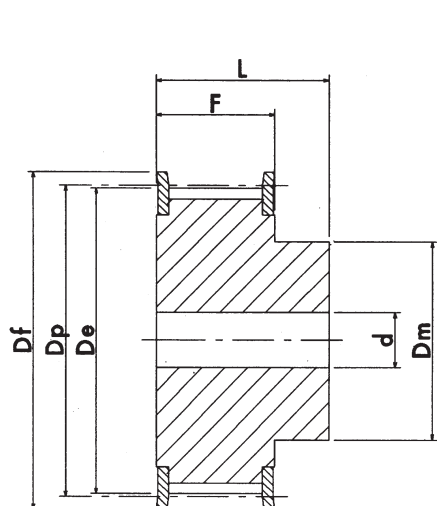

esecuzione 1F

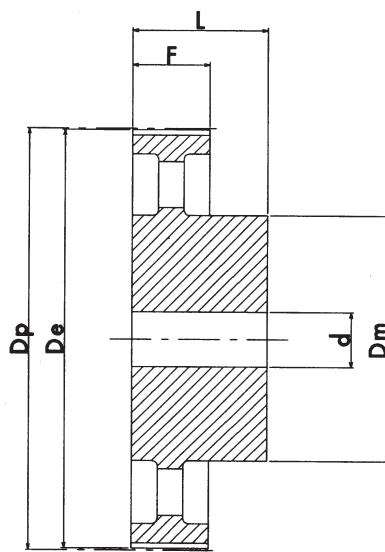

esecuzione 4

* Le dentature con l'asterisco vengono costruite a richiesta

TIPO: XH 200 PASSO 7/8" (22.22mm.)

CARATTERISTICHE		Typo	ESEC.	N. denti	Dp PRIMITIVO	De ESTERNO	Df FLANGIA	Dm MOZZO	F	L	d	FLANGIA N.
ACCIAIO	CON FLANGIA	18 XH 200	1F	18	127.34	124.55	140.0	100	65	80	24	155
		19 XH 200	1F	19	134.41	131.62	146.0	100	65	80	24	156
		20 XH 200	1F	20	141.49	138.69	155.0	100	65	80	24	157
		21 XH 200	1F	21	148.56	145.77	160.0	110	65	80	24	158
		22 XH 200	1F	22	155.64	152.84	170.0	110	65	80	24	159
		24 XH 200	1F	24	169.79	166.99	184.0	120	65	80	24	161
		25 XH 200	1F	25	176.86	174.07	188.0	120	65	80	24	162
		26 XH 200	1F	26	183.93	181.14	198.0	120	65	80	24	163
		27 XH 200	1F	27	191.01	188.22	205.0	120	65	80	24	164
		28 XH 200	1F	28	198.09	195.29	212.0	120	65	80	24	165
		30 XH 200	1F	30	212.23	209.44	227.0	120	65	80	24	167
		32 XH 200	1F	32	226.38	223.59	240.0	120	65	80	24	169
		34 XH 200	1F	34	240.53	237.74	256.0	120	65	80	24	170
		GHISA	SENZA FLANGIA	*38 XH 200	4	38	268.83	266.03	-	150	65	80
*40 XH 200	4			40	282.98	280.18	-	150	65	100	28	-
*48 XH 200	4			48	339.57	336.78	-	150	65	100	28	-
*60 XH 200	4			60	424.47	421.67	-	150	65	100	28	-
*72 XH 200	4			72	509.36	506.56	-	160	65	100	28	-
*84 XH 200	4			84	594.25	591.46	-	160	65	100	28	-
*96 XH 200	4			96	679.15	676.35	-	160	65	100	28	-
*120 XH 200	4			120	848.93	846.14	-	160	65	100	28	-

PULEGGE DENTATE POWERGRIP® PER CINGHIE POSITIVE

TIPO: XH 300 PASSO 7/8" (22.22mm.)

CARATTERISTICHE		Typo	ESEC.	N. denti	Dp PRIMITIVO	De ESTERNO	Df FLANGIA	Dm MOZZO	F	L	d	FLANGIA N.
ACCIAIO	CON FLANGIA	18 XH 300	1F	18	127.34	124.55	140.0	100	90.5	110	28	155
		19 XH 300	1F	19	134.41	131.62	146.0	100	90.5	110	28	156
		20 XH 300	1F	20	141.49	138.69	155.0	100	90.5	110	28	157
		21 XH 300	1F	21	148.56	145.77	160.0	110	90.5	110	28	158
		22 XH 300	1F	22	155.64	152.84	170.0	110	90.5	110	28	159
		24 XH 300	1F	24	169.79	166.99	184.0	120	90.5	110	28	161
		25 XH 300	1F	25	176.86	174.07	188.0	120	90.5	110	28	162
		26 XH 300	1F	26	183.93	181.14	198.0	120	90.5	110	28	163
		27 XH 300	1F	27	191.01	188.22	205.0	120	90.5	110	28	164
		28 XH 300	1F	28	198.09	195.29	212.0	150	90.5	110	28	165
		30 XH 300	1F	30	212.23	209.44	227.0	150	90.5	110	28	167
		32 XH 300	1F	32	226.38	223.59	240.0	150	90.5	110	28	169
		34 XH 300	1F	34	240.53	237.74	256.0	150	90.5	110	28	170
		GHISA	SENZA FLANGIA	*38 XH 300	4	38	268.83	266.03	-	150	90.5	120
*40 XH 300	4			40	282.98	280.18	-	150	90.5	120	32	-
*48 XH 300	4			48	339.57	336.78	-	175	90.5	120	32	-
*60 XH 300	4			60	424.47	421.67	-	175	90.5	120	32	-
*72 XH 300	4			72	509.36	506.56	-	175	90.5	120	32	-
*84 XH 300	4			84	594.25	591.46	-	175	90.5	120	32	-
*96 XH 300	4			96	679.15	676.35	-	175	90.5	120	32	-
*120 XH 300	4			120	848.93	846.14	-	175	90.5	120	32	-

* Le dentature con l'asterisco vengono costruite a richiesta

TIPO: XH 400 PASSO 7/8" (22.22mm.)

CARATTERISTICHE		Typo	ESEC.	N. denti	Dp PRIMITIVO	De ESTERNO	Df FLANGIA	Dm MOZZO	F	L	d	FLANGIA N.
ACCIAIO	CON FLANGIA	18 XH 400	1F	18	127.34	124.55	140.0	100	118	132	32	155
		19 XH 400	1F	19	134.41	131.62	146.0	100	118	132	32	156
		20 XH 400	1F	20	141.49	138.69	155.0	100	118	132	32	157
		21 XH 400	1F	21	148.56	145.77	160.0	110	118	132	32	158
		22 XH 400	1F	22	155.64	152.84	170.0	110	118	132	32	159
		24 XH 400	1F	24	169.79	166.99	184.0	120	118	132	32	161
		25 XH 400	1F	25	176.86	174.07	188.0	120	118	132	32	162
		26 XH 400	1F	26	183.93	181.14	198.0	120	118	132	32	163
		27 XH 400	1F	27	191.01	188.22	205.0	120	118	132	32	164
		28 XH 400	1F	28	198.09	195.29	212.0	150	118	132	32	165
		30 XH 400	1F	30	212.23	209.44	227.0	150	118	132	32	167
		32 XH 400	1F	32	226.38	223.59	240.0	150	118	132	32	169
		34 XH 400	1F	34	240.53	237.74	256.0	150	118	132	32	170
		GHISA	SENZA FLANGIA	*38 XH 400	4	38	268.83	266.03	-	150	118	132
*40 XH 400	4			40	282.98	280.18	-	150	118	132	32	-
*48 XH 400	4			48	339.57	336.78	-	175	118	132	32	-
*60 XH 400	4			60	424.47	421.67	-	175	118	132	32	-
*72 XH 400	4			72	509.36	506.56	-	175	118	132	32	-
*84 XH 400	4			84	594.25	591.46	-	175	118	132	32	-
*96 XH 400	4			96	679.15	676.35	-	175	118	132	32	-
*120 XH 400	4			120	848.93	846.14	-	175	118	132	32	-

PULEGGE DENTATE POWERGRIP® PER CINGHIE POSITIVE

TIPO: XXH 200 PASSO 1" 1/4 (31.75mm.)

CARATTERISTICHE		Tipo	ESEC.	N. denti	Dp PRIMITIVO	De ESTERNO	Df FLANGIA	Dm MOZZO	F	L	d	FLANGIA N.
ACCIAIO	CON FLANGIA	18 XXH 200	1F	18	181.91	178.87	198.0	140	64.2	100	28	163
		20 XXH 200	1F	20	202.13	199.08	212.0	150	64.2	100	28	165
		22 XXH 200	1F	22	222.34	219.29	240.0	150	64.2	100	28	169
		24 XXH 200	1F	24	242.55	239.50	267.0	150	64.2	100	28	173
		26 XXH 200	1F	26	262.76	259.79	290.0	150	64.2	100	28	178
GHISA	SENZA FLANGIA	*30 XXH 200	4	30	303.19	300.14	-	150	64.2	100	28	-
		*40 XXH 200	4	40	404.25	401.21	-	150	64.2	100	28	-
		*48 XXH 200	4	48	485.10	482.06	-	175	64.2	120	32	-
		*60 XXH 200	4	60	606.38	603.33	-	175	64.2	120	32	-
		*72 XXH 200	4	72	727.66	724.61	-	175	64.2	120	38	-
		*90 XXH 200	4	90	909.57	906.52	-	175	64.2	120	38	-

* Le dentature con l'asterisco vengono costruite a richiesta

TIPO: XXH 300 PASSO 1" 1/4 (mm 31.75)

CARATTERISTICHE		Tipo	ESEC.	N. denti	Dp PRIMITIVO	De ESTERNO	Df FLANGIA	Dm MOZZO	F	L	d	FLANGIA N.
ACCIAIO	CON FLANGIA	18 XXH 300	1F	18	181.91	178.87	198.0	140	91.4	110	28	163
		20 XXH 300	1F	20	202.13	199.08	212.0	150	91.4	110	28	165
		22 XXH 300	1F	22	222.34	219.29	240.0	150	91.4	110	28	169
		24 XXH 300	1F	24	242.55	239.50	267.0	150	91.4	110	28	173
		26 XXH 300	1F	26	262.76	259.79	290.0	150	91.4	110	28	178
GHISA	SENZA FLANGIA	*30 XXH 300	4	30	303.19	300.14	-	150	91.4	110	28	-
		*40 XXH 300	4	40	404.25	401.21	-	150	91.4	110	28	-
		*48 XXH 300	4	48	485.10	482.06	-	175	91.4	120	32	-
		*60 XXH 300	4	60	606.38	603.33	-	175	91.4	120	32	-
		*72 XXH 300	4	72	727.66	724.61	-	175	91.4	120	38	-
		*90 XXH 300	4	90	909.57	906.52	-	175	91.4	120	38	-

PULEGGE DENTATE POWERGRIP® PER CINGHIE POSITIVE

TIPO: XXH 400 PASSO 1" 1/4 (31.75mm.)

CARATTERISTICHE		Tipo	ESEC.	N. denti	Dp PRIMITIVO	De ESTERNO	Df FLANGIA	Dm MOZZO	F	L	d	FLANGIA N.
ACCIAIO	CON FLANGIA	18 XXH 400	1F	18	181.91	178.87	198.0	140	118.2	140	32	163
		20 XXH 400	1F	20	202.13	199.08	212.0	150	118.2	140	32	165
		22 XXH 400	1F	22	222.34	219.29	240.0	150	118.2	140	32	169
		24 XXH 400	1F	24	242.55	239.50	267.0	150	118.2	140	32	173
		26 XXH 400	1F	26	262.76	259.79	290.0	150	118.2	140	32	178
GHISA	SENZA FLANGIA	*30 XXH 400	4	30	303.19	300.14	-	185	118.2	140	32	-
		*40 XXH 400	4	40	404.25	401.21	-	185	118.2	140	32	-
		*48 XXH 400	4	48	485.10	482.06	-	185	118.2	140	38	-
		*60 XXH 400	4	60	606.38	603.33	-	185	118.2	140	38	-
		*72 XXH 400	4	72	727.66	724.61	-	220	118.2	140	38	-
		*90 XXH 400	4	90	909.57	906.52	-	220	118.2	140	38	-

* Le dentature con l'asterisco vengono costruite a richiesta

TIPO: XXH 500 PASSO 1" 1/4 (mm 31.75)

CARATTERISTICHE		Tipo	ESEC.	N. denti	Dp PRIMITIVO	De ESTERNO	Df FLANGIA	Dm MOZZO	F	L	d	FLANGIA N.
ACCIAIO	CON FLANGIA	18 XXH 500	1F	18	181.91	178.87	198.0	140	145.3	168	32	163
		20 XXH 500	1F	20	202.13	199.08	212.0	150	145.3	168	32	165
		22 XXH 500	1F	22	222.34	219.29	240.0	150	145.3	168	32	169
		24 XXH 500	1F	24	242.55	239.50	267.0	150	145.3	168	32	173
		26 XXH 500	1F	26	262.76	259.79	290.0	150	145.3	168	32	178
GHISA	SENZA FLANGIA	*30 XXH 500	4	30	303.19	300.14	-	215	145.3	168	32	-
		*40 XXH 500	4	40	404.25	401.21	-	215	145.3	168	32	-
		*48 XXH 500	4	48	485.10	482.06	-	215	145.3	168	38	-
		*60 XXH 500	4	60	606.38	603.33	-	240	145.3	168	38	-
		*72 XXH 500	4	72	727.66	724.61	-	240	145.3	168	38	-
		*90 XXH 500	4	90	909.57	906.52	-	240	145.3	168	38	-