



## Companies



### GERMANY

ACE STOSSDÄMPFER GMBH

Albert-Einstein-Straße 15  
40764 Langenfeld, Germany  
Tel.: +49-(0) 2173-9226-10  
Fax: +49-(0) 2173-9226-19  
[www.ace-ace.de](http://www.ace-ace.de)



### GREAT BRITAIN

ACE CONTROLS INTERNATIONAL

Unit 404 Easter Park, Haydock Lane  
Haydock, WA11 9TH, U.K.  
Tel.: +44-(0) 1942 727440  
Fax: +44-(0) 1942 717273  
[www.ace-controls.co.uk](http://www.ace-controls.co.uk)



### INDIA

ACE AUTOMATION CONTROL

EQUIPMENT PVT. LTD.  
Kaydon House, 2/396 A, Mookambigai Nagar  
Kattuppakkam, Iyyapanthangal, Chennai - 600 056, India  
Tel.: +91-44 24768484  
Fax: +91-44 24766811 / 911  
[www.acecontrols.in](http://www.acecontrols.in)



### JAPAN

ACE CONTROLS JAPAN L.L.C.

Room 31 Tanaka Bldg.  
2-9-6 Kanda-Tacho  
Chiyoda-Ku  
Tokyo 101-0046, Japan  
Tel.: +81-3 52 97 25 10  
Fax: +81-3 52 97 25 17  
[www.acecontrols.co.jp](http://www.acecontrols.co.jp)



### CHINA

ACE CONTROLS (SUZHOU) CO. LTD.

Building 7 East, No. 369 Lushan Road, Suzhou  
Jiangsu Province 215129, P.R. China  
Tel.: +86-(512) 88606699  
Fax: +86-(512) 88606698  
[www.acecontrols.cn.com](http://www.acecontrols.cn.com)



### USA

ACE CONTROLS INTERNATIONAL INC.

PO Box 71, Farmington  
Michigan 48024, USA  
Tel.: +1-248-476-0213  
Fax: +1-248-476-2470  
[www.acecontrols.com](http://www.acecontrols.com)





# *Tuning For Your Pressing Tools*

*Innovative damping solutions in the automobile and household appliance industry*

**NEW**



## The new design of ACE down holder damper

The innovative down holder damper made of co-polyester elastomer results in a new solution as a damper in pressing tools and replaces overloaded PU springs.

Sheet metal forming is increasingly taking place in the automobile and household appliance industry with faster cycling speeds. When opening the press after the pressing process, the holding screws and therefore the actual tool are substantially protected. Due to the increasing return stroke speeds, the forces on the down holder dampers have increased significantly and the PU springs cannot meet the new conditions.

The PU springs often literally crumble after just a few cycles and leave holding screws, tools and down holders without protection. The holding screws tear-off and cause production failures and significant repair costs for the tools. As a result, the TUBUS-Special for holding screws from M10 to M30 were developed. The maximum energy absorption is between 5 Nm and 269 Nm.

### **In comparison to the standard PU springs, the TUBUS down holder dampers offer:**

- > A high service life and operational safety
- > High force and energy absorption
- > High effectiveness level
- > Low setting behaviour
- > Noise reduction
- > UV protection
- > Low abrasion
- > Efficient work with higher cycle speeds
- > More design freedom when setting up new tools

### **TUBUS-Special-D00015 (Down Holder Damper M16)**

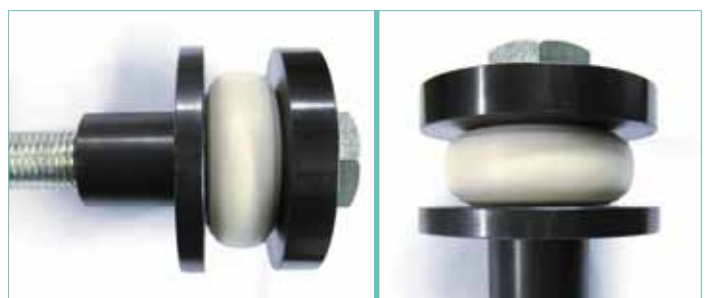

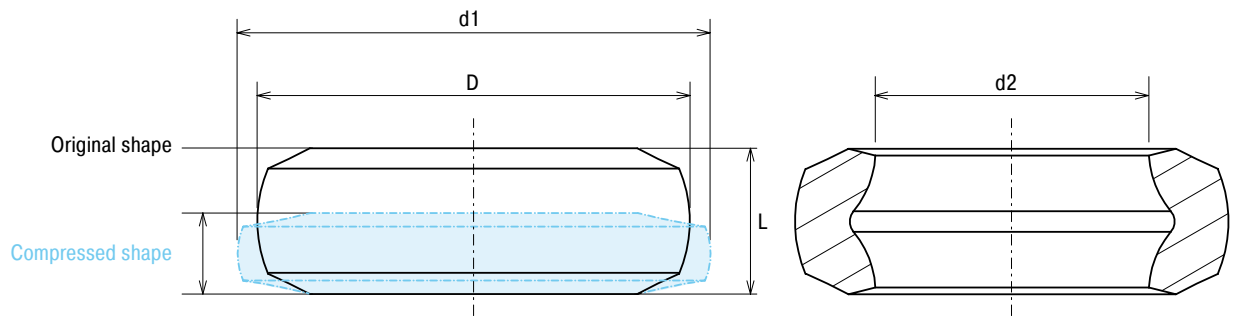

### Dimensions and Capacity Chart

Type	Retainer screws	Standard	Ident-No.	$W_3$ Nm/Hub	F max. N	max. Stroke mm	D	$d_1$	$d_2$	L	Material hardness Rating
D00002	M10	BMW	2 173 880	5.0	5500	2.0	26.4	28.4	16.3	7.8	Shore 55D
D00003*	M12	BMW	2 173 881	14.2	9000	4.4	32.1	35.1	20.3	10.8	Shore 72D
D00015*	M16	BMW	2 173 882	44.6	20000	4.9	45.8	49.8	25.3	17.0	Shore 72D
D00013	M20	BMW	2 173 883	81.9	30000	7.6	54.6	61.8	30.3	21.3	Shore 55D
D00006	M24	BMW	2 173 884	126.5	46000	8.2	61.8	69.9	36.3	21.5	Shore 55D
D00014	M30	BMW	2 173 885	269.0	75000	11.4	78.5	89.0	42.8	29.4	Shore 55D
D00020	M16	Daimler	prototype	3.8	5000	1.7	29.3	30.7	16.7	8.1	Shore 55D
D00021	M20	Daimler	prototype	11.3	10000	3.0	32.2	35.9	20.3	9.5	Shore 55D
D00047	M24	Daimler	prototype	16.3	11000	2.7	51.8	53.7	33.3	16.9	Shore 55D
D00048	M24	Daimler	prototype	28.1	14600	3.4	58.5	62.6	38.7	17.8	Shore 55D
D00044	M10	ThyssenKrupp	prototype	3.0	3000	2.0	23.6	25.0	16.0	7.3	Shore 55D
D00045	M20	ThyssenKrupp	prototype	14.0	11000	4.1	43.3	47.6	30.0	10.2	Shore 55D
D00046	M24	ThyssenKrupp	prototype	16.3	11000	2.7	51.8	53.7	33.3	16.9	Shore 55D

\*Natural colour: without additional UV protection  
 Dimensions: Tolerance to DIN 16901

**Environment:** resistant against microbes, seawater, chemicals and with very good UV resistance.

No absorption of water and no swelling.

**Operating temperature range:** -40°C to 90°C

**Upon request:** special strokes, characteristics, sizes and materials.

More individual damping solutions for different tool standards are possible.

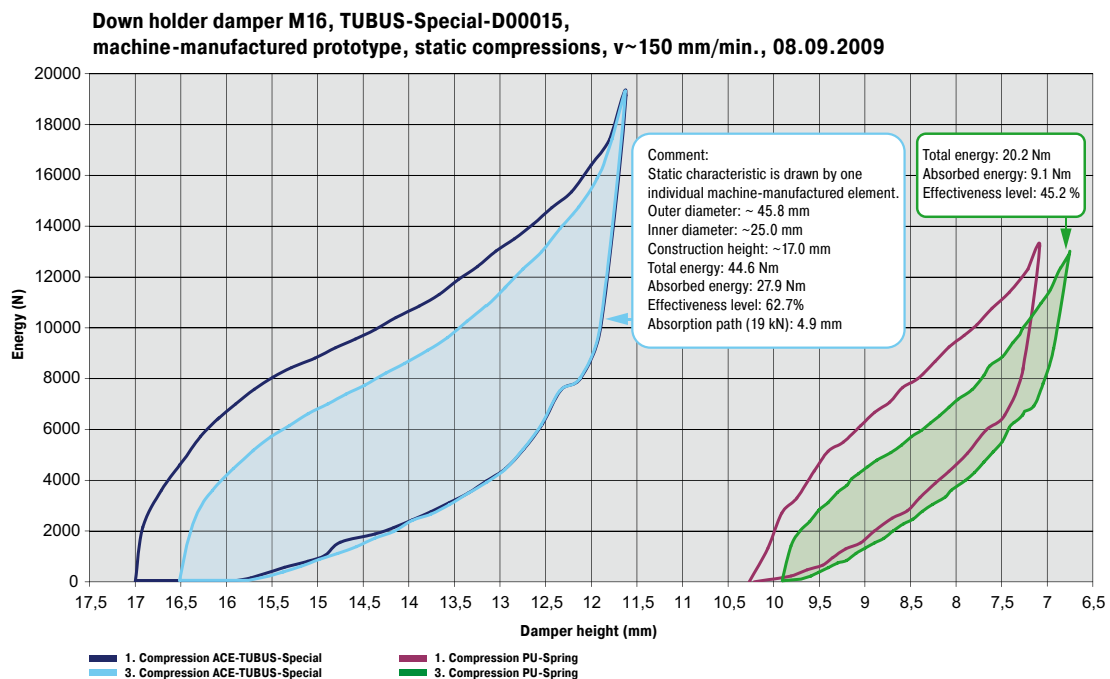

Graphic: From customer supplied PU Spring.

### ACE Lift Damper – the Down Holder Damper’s Brother

Due to the high speeds, especially in the modern ProgDie presses, the problems for the end position damping of the original PU springs are the same as the Down Holder resulting in tool damage, production failure and very high repair costs.

The ACE lift dampers made of co-polyester elastomer sit on the holding screws of the spring loaded guide pillars or lifters in the lower part of the tool of the progressive die. In the actual pressing process, the spring loaded guide pillars and lifter are pressed downwards with the sheet. After the pressing process, they are pressed back up with the reshaped sheet metal using gas springs. The holder screws are used for lift limitation for the guide pillars and lift dampers protect in the same way as the down holders and make the following working stages possible.

**In comparison to the standard PU springs, the TUBUS lift dampers offer:**

- > A high service life and operational safety
- > High force and energy absorption
- > High effectiveness level
- > Low setting behaviour
- > Noise reduction
- > UV protection
- > Low abrasion
- > Efficient work with higher cycle speeds
- > More design freedom when setting up new tools

**TUBUS-Special-D00038 (Lift damper M12)**



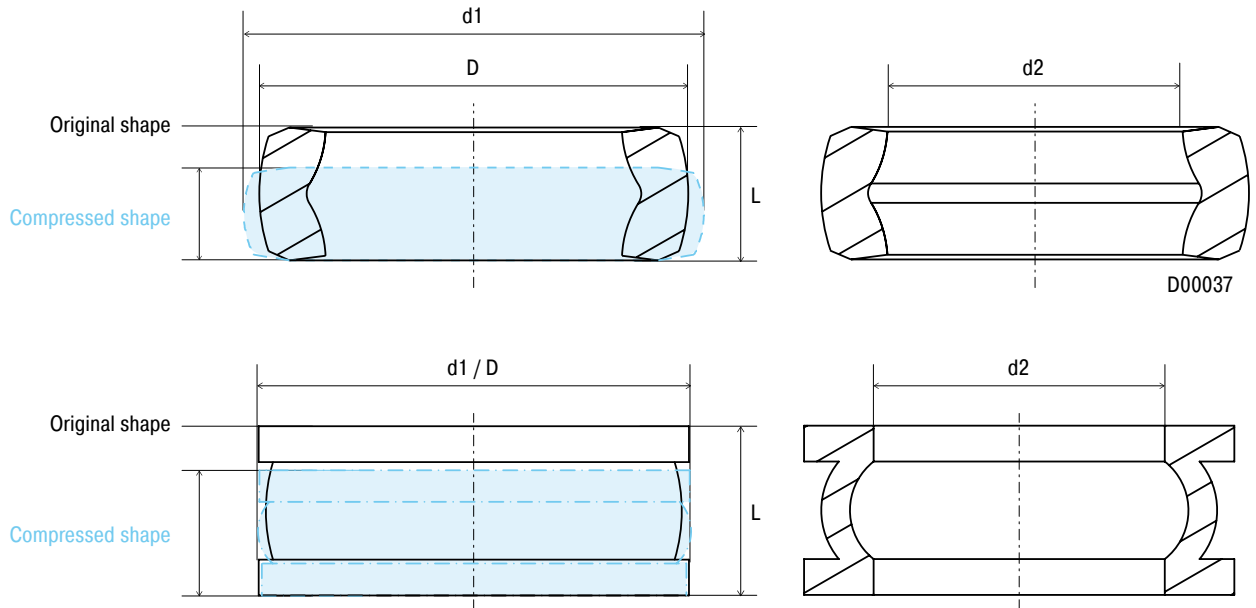

The damping elements in flange style (D00018/D00038) can apply a force or depending on the stroke can be double layer without the need for an additional spacer washer.

#### Dimensions and Capacity Chart

Type	Retainer screws	Standard	Ident-Nr.	$W_3$ Nm/Hub	F max. N	max. Stroke mm	D	$d_1$	$d_2$	L	Material hardness Rating
D00037*	M10	BMW	2 173 878	3.0	3 000	2.0	23.6	25.3	16.3	7.3	Shore 55D
D00038*	M12	BMW	2 173 879	8.6	5 000	2.9	30.0	30.2	20.3	11.8	Shore 72D
D00018**	none	Daimler	B8 1130 0277019	4.5	2 500	4.4	39.5	39.6	33.0	13.2	Shore 55D

\*Natural colour: without additional UV protection

\*\*Sits on a guide pillar gas spring in the lift unit

Dimensions: Tolerance to DIN 16901

**Environment:** resistant against microbes, seawater, chemicals and with very good UV resistance.

No absorption of water and no swelling.

**Operating temperature range:** -40°C to 90°C

**Upon request:** special strokes, characteristics, sizes and materials.

More individual damping solutions for different tool standards are possible.

**Lift Damper M12, TUBUS-Special-D00038,  
3rd static compressions, v~40 mm/min., 06.09.2010**

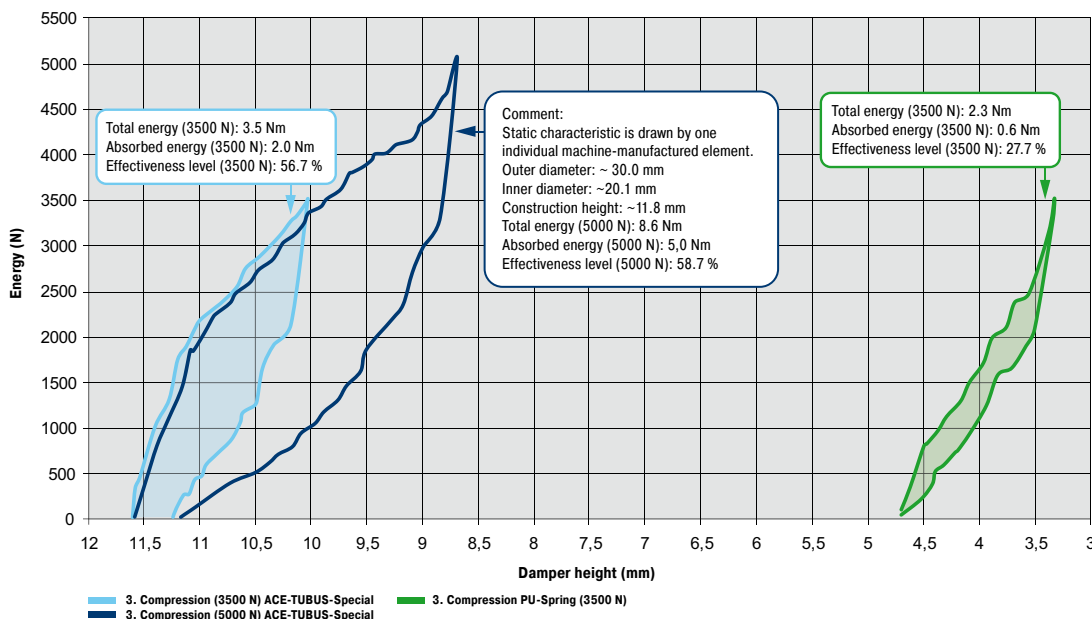

Graphic: From customer supplied PU Spring.

## ACE Damping Plugs – a new design in emergency stops

The function of the innovative damping plugs made of co-polyester elastomer is the same as the down holder dampers. However, they are located to the side of the down holder and are loaded radially.

The metal sheets are located and held firmly by the down holder to achieve clean forming. After the pressing process, the heavily accelerated tool top section drives upwards into the start position and takes the down holder with it. The plug bolts hit against the damping elements. Due to the high speeds of the new presses, the previously used PU elements were overloaded and cannot deal with the high peak forces.

The damping plugs are available in four different sizes and are mainly used in large tools. The number and size depends on the weight and speed of the down holder.

### **In comparison to the standard PU springs, the TUBUS Damping plugs offer:**

- > A high service life and operational safety
- > High force and energy absorption
- > High effectiveness level
- > Low setting behaviour
- > Noise reduction
- > UV protection
- > Low abrasion
- > Efficient work with higher cycle speeds
- > More design freedom when setting up new tools



**Environment:** resistant against microbes, seawater, chemicals and with very good UV resistance. No absorption of water and no swelling.

**Operating temperature range:** -40°C to 90°C

**Upon request:** special strokes, characteristics, sizes and materials. More individual damping solutions for different tool standards are possible.

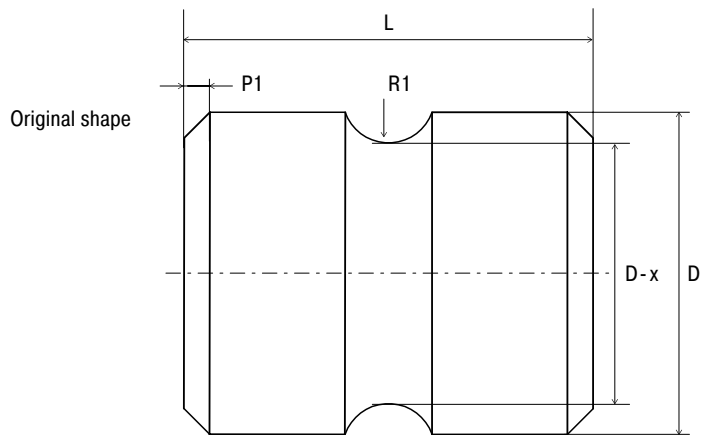

### Dimensions and Capacity Chart

Type TUBUS-Special	Frame size	Standard	Ident-No.	D	D - x recess depth	R1 recess radius	P1	L	Material hardness Rating
D00023	B	BMW	2 173 697	40	40 - 8	7	3 x 45°	60	Shore 40D
D00024	C	BMW	2 173 698	50	50 - 10	8	4 x 45°	70	Shore 40D
D00035	D	BMW	2 173 699	63	63 - 12	9	5 x 45°	80	Shore 45D
D00036	E	BMW	2 173 700	80	80 - 14	10	6 x 45°	90	Shore 45D

### Installation of a Damping Plug

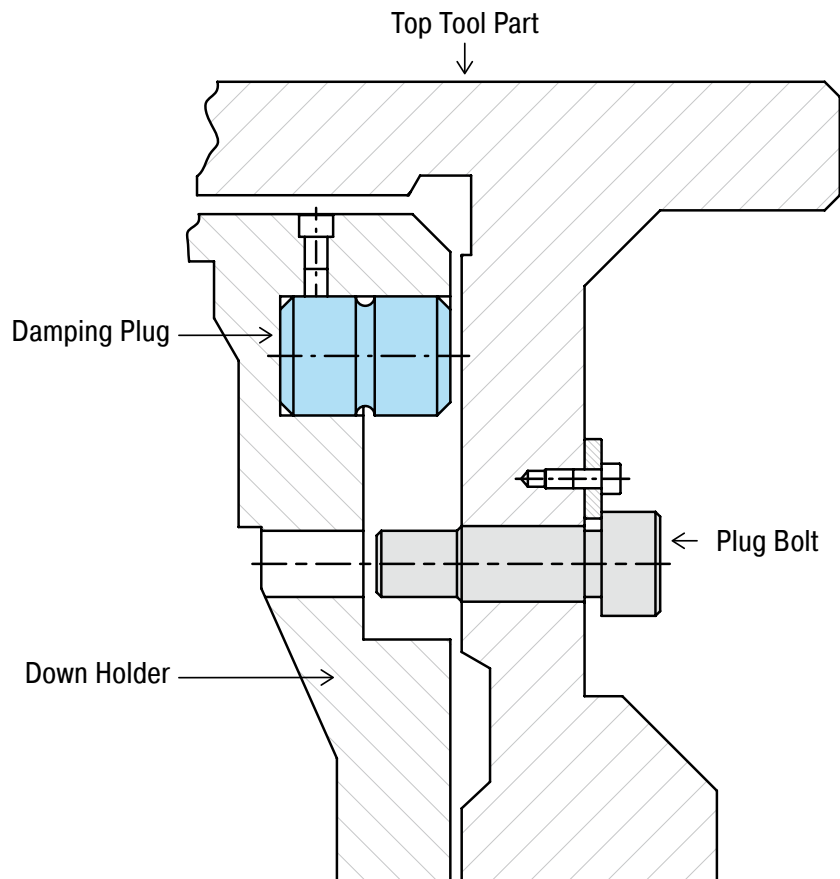



### ACE Press Dampers – when side load (almost) becomes the main consideration

All new innovative damping solutions for the pressing tools have, apart from their other properties, one thing in common: they also reduce noise.

While this only plays a subordinate role for other dampers, this aspect has significant importance in pressing dampers. These special damping elements are used in dies for eccentric/toggle presses by manufacturers of large household appliances. The achieved cycle rates and speeds are much higher than in automotive industrial presses and result in correspondingly higher noise levels. Reducing this is the actual task of these elements.

The processed sheet metal parts are also fixed by the down holder. In order to achieve a clean reshaping process, the process is additionally supported by gas springs. They are located in the top tool part and provide the necessary forces from above onto the sheet metal holder and the sheet metal material. When closing the press, the piston rods on the gas springs hit against the down holder without being damped. The press dampers are located in a good close-fitting pocket. The initial test results confirmed a noise reduction from 91 dB to 89 dB.

**ACE Press Dampers, TUBUS-Special-D00042, machine-manufactured prototype, static compressions, v~70 mm/min., 13.04.2011**

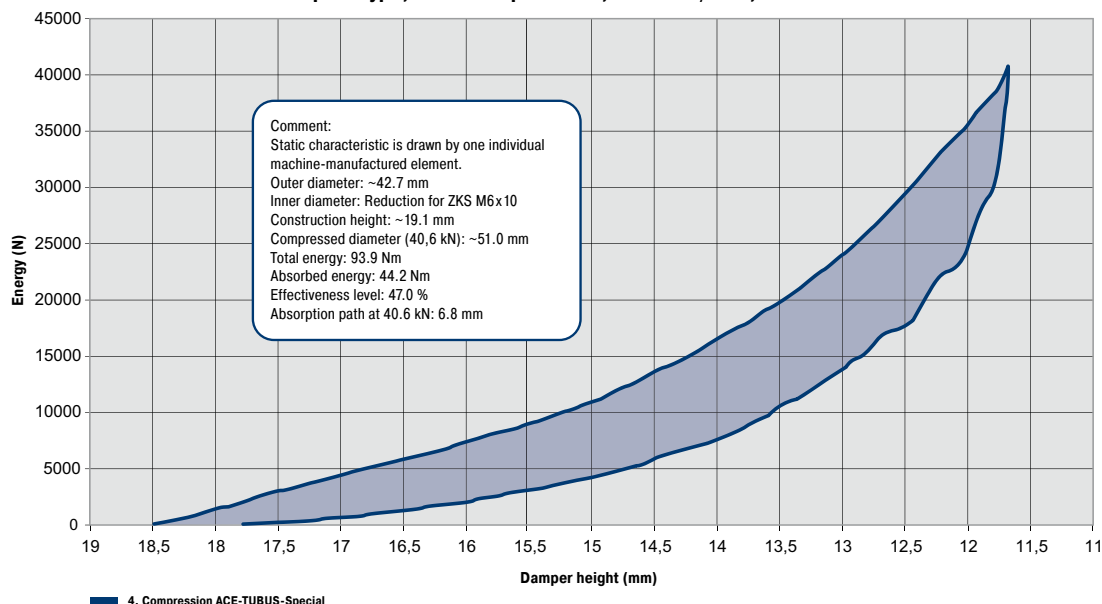

The dampers are generally designed depending on the space and force specifications. The number and size of holding screws with the corresponding damping elements are specified using the sheet for a new tool. For retrofitting existing tools, the damper can be designed using the holding screws.

**Checking the previously used dampers aids design (see comparison curves on page 3 and page 5).**

**General Principles for Design of the Special Dampers for Pressing Tools**

- Type of damping (depending on construction type): \_\_\_\_\_
- Return stroke speed when opening the press: \_\_\_\_\_
- Down holder weight: \_\_\_\_\_
- Number of retaining screws: \_\_\_\_\_
- Inner diameter of dampers (depending on the diameter of the holding screws or spacer sleeves): \_\_\_\_\_
- Max. outer diameter of dampers: \_\_\_\_\_
- Max. Number of tool strokes per minute: \_\_\_\_\_
- Max. damper construction height: \_\_\_\_\_
- Possible damping: \_\_\_\_\_

**Other principles for the design of lift dampers**

- Max. extension force of the gas springs in the lift unit: \_\_\_\_\_
- Dimensions of the lift unit (if the damper does not sit on the holding screw): \_\_\_\_\_

**Additional information for the design of the lifting Dampers**

- Max. extension force of the gas springs in the top tool part: \_\_\_\_\_
- Number of gas springs: \_\_\_\_\_
- Piston rod diameter of gas springs: \_\_\_\_\_
- Possible diameter and depth of the drill pocket in the down holder: \_\_\_\_\_

- Special features: \_\_\_\_\_
- \_\_\_\_\_
- Requirement/per year: \_\_\_\_\_ ■ Tool type: \_\_\_\_\_

Company Stamp

Company: \_\_\_\_\_

Name: \_\_\_\_\_

Department/Position: \_\_\_\_\_

Street/PO Box: \_\_\_\_\_

Postcode/City: \_\_\_\_\_

Telephone: \_\_\_\_\_ Fax: \_\_\_\_\_

E-Mail: \_\_\_\_\_

Internet: \_\_\_\_\_

**Please copy, complete and fax to ACE: +49-(0)2173-9226-89**